

# KENWOOD

COMPACT HI-FI SYSTEM

## XD-SERIES

XD-A83

XD-853

XD-803

---

## INSTRUCTION MANUAL

KENWOOD CORPORATION

**This instruction manual is used to describe multiple models listed above.  
Model availability and features (functions) may differ depending on the country  
and sales area.**

→ 64



# 2 Before applying power

⚠ **Caution** : Read this page carefully to ensure safe operation.

Units are designed for operation as follows.

**U.S.A. and Canada** ..... **AC 120 V only**  
**Australia** ..... **AC 240 V only**

**Europe and U.K.** ..... **AC 230 V only**  
**China and Russia** ..... **AC 220 V only**  
**\*Other countries** ..... **AC 110-120 / 220-240 V switchable**

## For the United Kingdom

### Factory fitted moulded mains plug

1. The mains plug contains a fuse. For replacement, use only a 13-Amp ASTA-approved (BS1362) fuse.
2. The fuse cover must be refitted when replacing the fuse in the moulded plug.
3. Do not cut off the mains plug from this equipment. If the plug fitted is not suitable for the power points in your home or the cable is too short to reach a power point, then obtain an appropriate safety approved extension lead or adapter, or consult your dealer.

If nonetheless the mains plug is cut off, remove the fuse and dispose of the plug immediately, to avoid a possible shock hazard by inadvertent connection to the mains supply.

**IMPORTANT:** The wires in the mains lead are colored in accordance with the following code:  
Blue : Neutral  
Brown : Live

Do not connect those leads to the earth terminal of a three-pin plug.

### \*AC voltage selection

The AC voltage selector switch on the rear panel is set to the voltage that prevails in the area to which the unit is shipped. Before connecting the power cord to your AC outlet, make sure that the setting position of this switch matches your line voltage. If not, it must be set to your voltage in accordance with the following direction.

### AC voltage selector switch

Move switch lever to match your line voltage with a small screwdriver or other pointed tool.

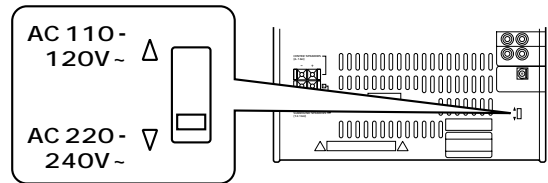

### Note:

Our warranty does not cover damage caused by excessive line voltage due to improper setting of the AC voltage selector switch.

Preparation section

## Safety precautions

**WARNING** : TO PREVENT FIRE OR ELECTRIC SHOCK, DO NOT EXPOSE THIS APPLIANCE TO RAIN OR MOISTURE.

|  |   |  |   |
|--|---|--|---|
|  | <b>CAUTION</b><br>RISK OF ELECTRIC SHOCK<br>DO NOT OPEN   |  | CAUTION: TO REDUCE THE RISK OF ELECTRIC SHOCK, DO NOT REMOVE COVER (OR BACK). NO USER-SERVICEABLE PARTS INSIDE. REFER SERVICING TO QUALIFIED SERVICE PERSONNEL. |
|  | THE LIGHTNING FLASH WITH ARROWHEAD SYMBOL, WITHIN AN EQUILATERAL TRIANGLE, IS INTENDED TO ALERT THE USER TO THE PRESENCE OF UNINSULATED "DANGEROUS VOLTAGE" WITHIN THE PRODUCT'S ENCLOSURE THAT MAY BE OF SUFFICIENT MAGNITUDE TO CONSTITUTE A RISK OF ELECTRIC SHOCK TO PERSONS. |  |   |
|  | THE EXCLAMATION POINT WITHIN AN EQUILATERAL TRIANGLE IS INTENDED TO ALERT THE USER TO THE PRESENCE OF IMPORTANT OPERATING AND MAINTENANCE (SERVICING) INSTRUCTIONS IN THE LITERATURE ACCOMPANYING THE APPLIANCE.  |  |   |

### The marking of products using lasers (Except for some areas)

**CLASS 1  
LASER PRODUCT**

The marking is located on the rear panel and says that the component uses laser beams that have been classified as Class 1. It means that the unit is utilizing laser beams that are of a weaker class. There is no danger of hazardous radiation outside the unit.

### The marking of products using lasers (Except for some areas)



**CAUTION**  
INVISIBLE LASER RADIATION  
WHEN OPEN. AVOID EXPOSURE TO BEAM.

Inside this laser product, a laser diode classified as Class 3A laser radiation is contained as alerted by the internal caution label shown above. To avoid exposure to laser beams, do not open the cover.

# Contents

Caution : Read the pages marked  carefully to ensure safe operation.

## Preparation section

|   |    |
|---|----|
|  <b>Before applying power</b> ..... | 2  |
|  <b>Safety precautions</b> .....    | 2  |
| <b>Special features</b> .....   | 4  |
| <b>System connection</b> .....  | 5  |
| <b>Accessories</b> .....  | 5  |
| <b>Connection of the system accessories</b> .....   | 5  |
| <b>Connection with other components (optional or commercially-available equipment)</b> .....                        | 8  |
| <b>Controls and indicators</b> .....  | 10 |
| <b>Main unit</b> .....  | 10 |
| <b>Display</b> .....  | 12 |
| <b>Remote control unit</b> .....  | 13 |
| <b>Operation of remote control unit</b> .....   | 14 |
| <b>Operation of the jog dial</b> .....  | 15 |
| <b>Clock adjustment</b> .....   | 16 |
| <b>Changing the display language</b> .....  | 17 |

## Basic section

|  |    |
|--|----|
| <b>Let's have sound</b> .....            | 18 |
| <b>Basic operation</b> .....             | 18 |
| <b>Playback of CD</b> .....              | 20 |
| <b>Tape playback</b> .....               | 22 |
| <b>CHANNEL SPACE setting</b> .....       | 25 |
| <b>Receiving broadcast station</b> ..... | 26 |
| <b>Let's record</b> .....                | 28 |
| <b>Recording on TAPE</b> .....           | 28 |
| <b>Copying tape (Tape dubbing)</b> ..... | 31 |

## Application section

|   |    |
|---|----|
| <b>Playback of CD</b> .....   | 32 |
| <b>Listening in the desired sequence (program playback)</b> .....   | 32 |
| <b>Repeated playback</b> .....                                      | 34 |
| <b>Random playback</b> .....  | 36 |
| <b>R.D.S. (Radio Data System) (For U.K. and Europe)</b> .....       | 37 |
| <b>Searching for a desired program type (PTY search)</b> .....      | 38 |
| <b>Convenient CD recording</b> .....                                | 40 |
| <b>Selection of the recording type</b> .....                        | 40 |
| <b>Recording only desired titles (CD ONE TRACK RECORDING)</b> ..... | 41 |
| <b>Recording of an entire CD (CD DIRECT RECORDING)</b> .....        | 42 |
| <b>Recording the programmed titles (CD PROGRAM RECORDING)</b> ..... | 43 |
| <b>Effective sound adjustment</b> .....                             | 44 |
| <b>Balance adjustment</b> .....                                     | 44 |
| <b>Input level adjustment</b> .....                                 | 45 |
| <b>Listening to music with desired tone and sound field</b> .....   | 46 |
| <b>Equalizer pattern setting and saving</b> .....                   | 47 |
| <b>Surround setting</b> .....                                       | 48 |
| <b>Switching the AUX Input</b> .....                                | 50 |
| <b>Surround function</b> .....                                      | 50 |
| <b>Timer operation</b> .....  | 52 |
| <b>Sleep timer</b> .....  | 52 |
| <b>Timer programming</b> .....                                      | 53 |
| <b>Auto Power Save</b> .....  | 54 |

## Knowledge section

|  |    |
|--|----|
| <b>Handling of discs and tapes</b> ..... | 56 |
| <b>Important Items</b> .....             | 57 |
| <b>Maintenance</b> .....                 | 57 |
| <b>Reference</b> .....                   | 57 |
| <b>In case of difficulty</b> .....       | 58 |
| <b>Specifications</b> .....              | 62 |



As an ENERGY STAR® Partner, Kenwood Corporation has determined that this products meets the ENERGY STAR® guidelines for energy efficiency.

This product can save energy. Saving energy reduces air pollution and lowers utility bills.

## Dolby Pro Logic Surround, Dolby 3 Stereo Surround and Dolby Virtual Surround

Dolby Pro Logic Surround, Dolby 3 Stereo Surround and Dolby Virtual Surround are top-level surround modes that can reproduce the world of 3-dimensional audio.

## Simplified operations using large-sized, Jog Dial

### Multi-control jog dial (For use in selecting a function)

This dial allows you to set the CD program and timer-related operations while observing the operating conditions shown by the display.

## Multi language display function

The menu items for the operation can be displayed in any of five of languages, English, French, German, Spanish, and Italian.

## Large-sized color display panel

The large sound level meter represents the movement in music with brilliant colors to offer the joy of viewing the music at the same time as listening.

## 3-Disc carousel CD player

Three discs can be set. There are various ways for enjoyment at the time of program playback, repeat playback, random playback, etc.

## Convenient timer functions

**Timer programming :** Timer playback, AI timer playback, and timer recording can be programmed.

÷ **AI timer playback :** When the unit is turned ON by the timer, the sound level increases gradually.

**Sleep timer :** Useful when you want to go asleep while listening to music.

## CD text information display (CD TEXT compatibility)

The text information (disc title and track titles) recorded into CDs can be displayed.

## Demonstration

When the power supply is restored after a power failure or the power cord is unplugged and plugged in again during use, this unit automatically starts the demonstration function (display only). During the demonstration, the display changes in sequence but the sound mode does not change.

### To cancel :

Press the DISPLAY/DEMO key during demonstration to stop it.



### To switch on and off the demonstration :

Turn the unit OFF (STANDBY mode) and press the DISPLAY/DEMO key.

Each press of the key switches the demonstration as shown below.

- ① "Demo on" (Demonstration on)
- ② "Demo off" (Demonstration off)

## Accessories

**FM indoor antenna**  
(1)



**AM loop antenna**  
(1)

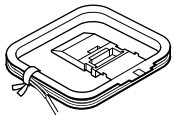

**Remote control unit**  
(1)

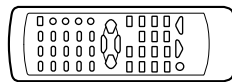

**Batteries (R6/AA)**  
(2)

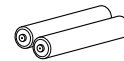

**AC plug adaptor (1)**

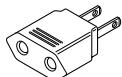

Use to adapt the plug on the power cord to the shape of the wall outlet. (Accessory only for regions where use is necessary.)

**Surround speaker system**

**Surround speaker (2)**

Speaker cord (2)  
Speaker stabilizer (8)

**Center speaker (1)**

Speaker cord (1)  
Speaker stabilizer (4)

### Unpacking

Unpack the unit carefully and make sure that all accessories are put aside so they will not be lost.

Examine the unit for any possibility of shipping damage. If your unit is damaged or fails to operate, notify your dealer immediately. If your unit was shipped to you directly, notify the shipping company without delay. Only the consignee (the person or company receiving the unit) can file a claim against the carrier for shipping damage.

We recommend that you retain the original carton and packing materials for use should you transport or ship the unit in the future.

**Keep this manual handy for future reference.**

## Connection of the system accessories

### CAUTION Note on Connection

Connect the components as shown in the diagram. Only plug the power cord into a power outlet once connections are completed. The rear panel configuration is variable depending on the models (countries or area).

#### FM indoor antenna

The accessory antenna is for temporary indoor use only. For stable signal reception we recommend using an outdoor antenna. Remove the indoor antenna if you connect one outdoors.

- 1 Connect to the antenna terminal.
- 2 Locate the position providing good reception condition.
- 3 Fix the antenna.

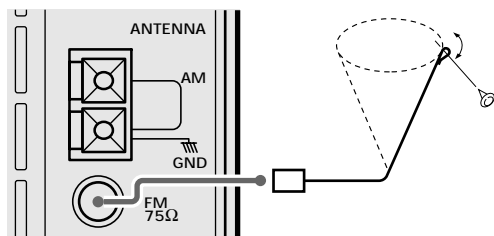

#### AM loop antenna

The supplied antenna is for indoor use. Place it as far as possible from the main system, TV set, speaker cords and power cord, and set it to a direction which provides the best reception.

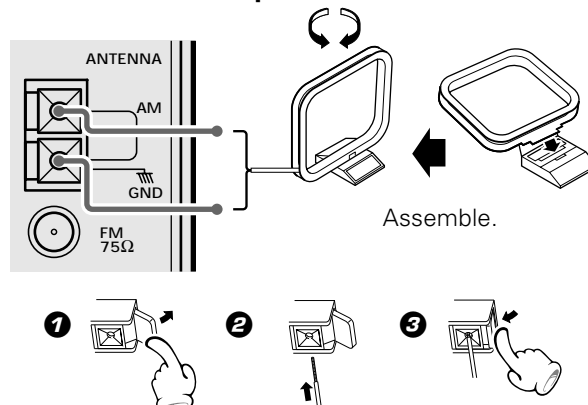

## Front Speakers

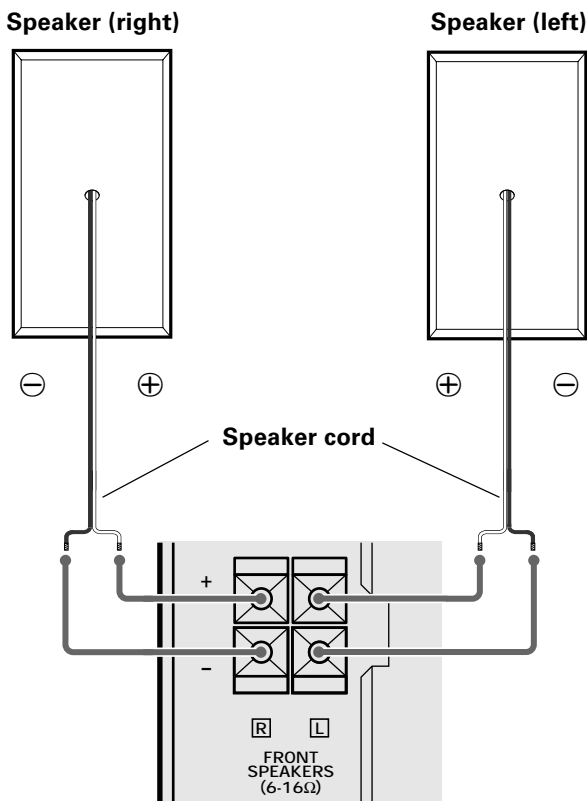

- ÷ Never short-circuit the "+" and "-" speaker cords.
- ÷ If the left and right speaker connections or the "+" and "-" polarity are inverted, the sound will be unnatural with unclear positioning of musical instruments, etc. Be sure to connect them properly.

| System Name | Front Speaker Model Name |
|-------------|--------------------------|
| XD-A83      | LS-N573                  |
| XD-853      | LS-N573                  |
| XD-803      | LS-N523                  |

### Main Unit

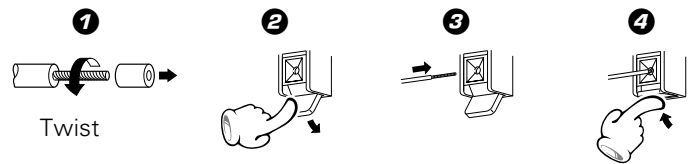

### Malfunction of microcomputer

If operation is not possible or erroneous display appears even though all connections have been made properly, reset the microcomputer. Refer to "In case of difficulty".



1. Be sure to insert all connection cords securely. If their connections are imperfect, the sound may not be produced or noise may interfere.
2. Before plugging or unplugging a connection cord, be sure to unplug the power cord from the wall AC outlet. If connection cords are plugged or unplugged with the power cord left plugged in, malfunction or damage may result.

### CAUTION (For U.S.A., U.S.-Military and Canada)

Be sure to adhere followings. Or proper ventilation will be blocked causing damage or fire hazard.

- ÷ Do not place any objects impairing heat radiation onto the top of unit.

### Speaker and TV installation

If there is a magnet or other device generating magnetic force nearby, interaction between the magnet and speaker may cause color blotching on the TV. If this happens, move the speaker at least 20 cm away from the TV set.

### CAUTION (Other countries)

Be sure to adhere followings. Or proper ventilation will be blocked causing damage or fire hazard.

- Do not place any objects impairing heat radiation onto the top of unit.
- Leave a space around the unit (from the largest outside dimension including projection) equal or greater than, shown below.

Top panel : 50 cm

Side panel : 10 cm

Back panel : 10 cm

## Surround speakers system

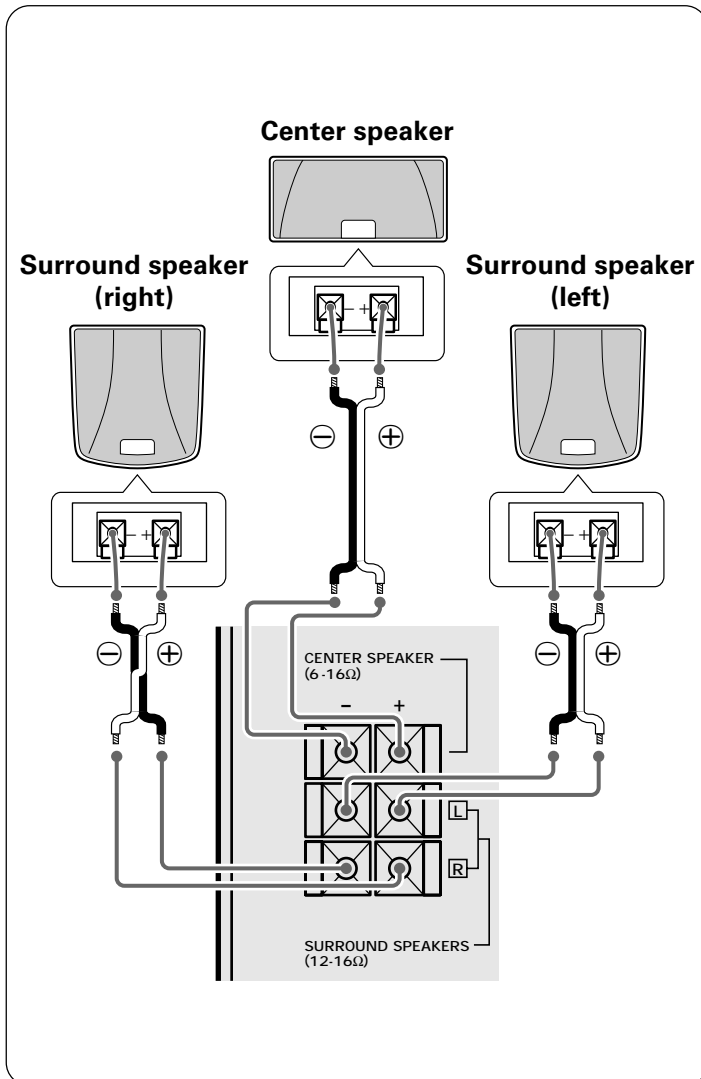

### How to use the speaker stabilizer (cushions)

When the surround speaker system installation is unstable due to the floor condition, apply the provided stabilizer (cushions) on four positions on the bottom of each speaker.

### Hanging on a wall (CRS-N553/CRS-N503)

The speakers can be hung on a wall by using the wall hanging holes on the back of the speaker. When hanging the speakers, select a rigid and hard place on the wall which can withstand the weight of the speakers.

1. Install a screw with sufficient strength on the wall. When screwing in, leave the head and upper stem of the screw projected by 7 to 9 mm from the wall surface.
2. Hang the speaker by inserting the screw into the wall hanging hole on the upper rear side of the speaker. Check that the speaker are firmly mounted.

÷ Before installation, check the wall or ceiling well to confirm that it is strong enough to withstand the weight of the speaker. KENWOOD cannot assume the responsibility against accidents caused by the drop of speaker due to insufficient mounting strength or to any defect in installation.

÷ The wall hanging screw is not provided. Please prepare a screw that can assure enough mounting strength according to the material and thickness (structure) of the wall where the speaker is to be hung.

÷ If the material or thickness of a wall or ceiling cannot be confirmed, consult a professional specialized in installation.

| System Name | Surround Speaker Model Name |
|-------------|-----------------------------|
| XD-A83      | CRS-N553                    |
| XD-853      | CRS-N553                    |
| XD-803      | CRS-N503                    |

### Main Unit

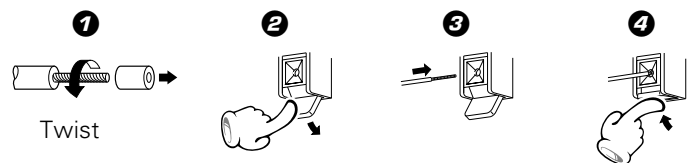

### Surround Speaker Unit

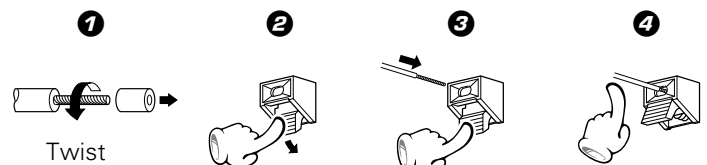

Before connecting the surround speakers system, be also sure to read "Surround setting" and "Surround function".

→ 48 → 50

### Recommended speaker installation

It is recommended that the surround speakers are installed straight to the left and right of the listening position or slightly behind, at a height of about 1 meter higher than the listener's ears. Each surround speaker should be installed so that the longer sides are horizontal.

## Connection with other components (optional or commercially-available equipment)

### CAUTION Note on Connection

Connect the components as shown in the diagram. Only plug the power cord into a power outlet once connections are completed. The rear panel configuration is varies depending on the model (countries or area).

### DVD player, Video recorder, MD recorder, etc.

DVD player, Video recorder, MD recorder, etc.

DVD player, etc. (6ch output)

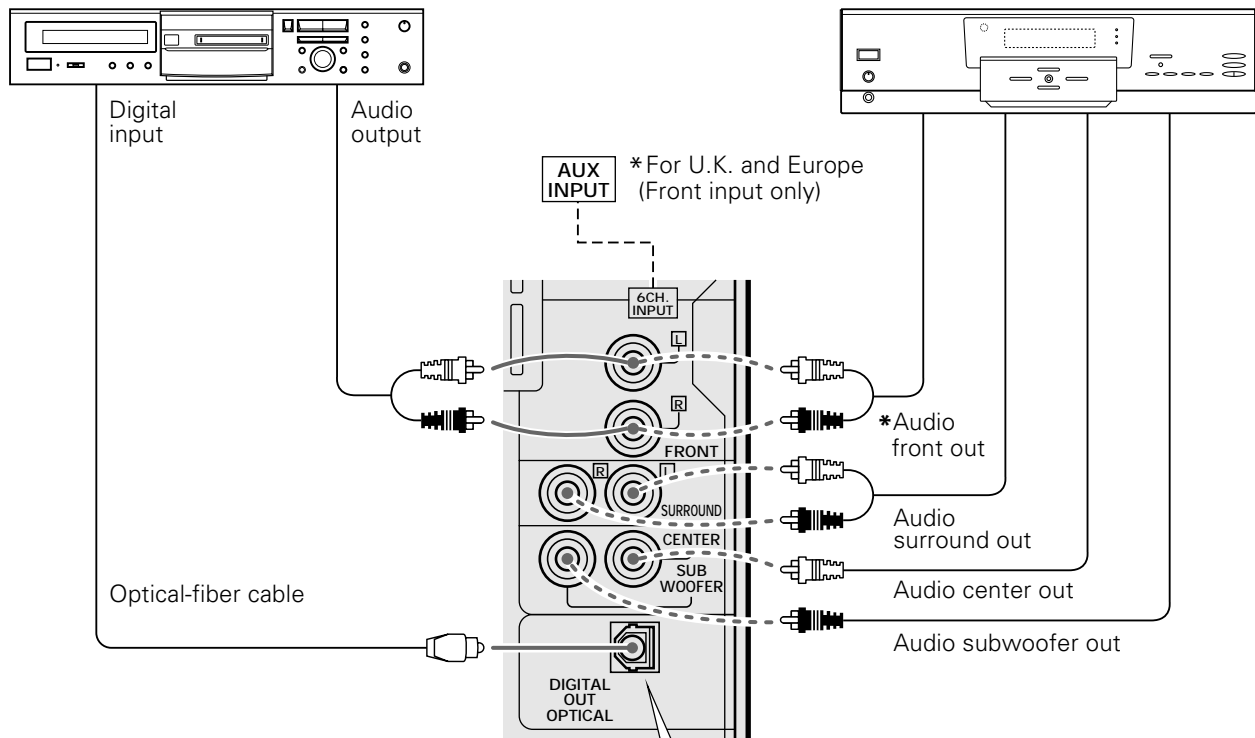

### DIGITAL OUT OPTICAL jack (Except for U.S.A. and Canada)

Remove the cap and plug the optical-fiber cable.

Optical-fiber cable  
(Provided with the MD recorder)

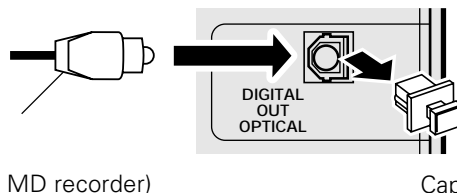

- ÷ Insert the optical-fiber cable straight into the connector until it clicks.
- ÷ Be sure to attach the protection cap when the connector is not used.
- ÷ Never bend or bundle up the optical-fiber cable.



When an external system component is connected, please read the instruction manual of the component as well.



### Super woofer

Extremely low sound is played back powerfully.

(SW-500/optional)

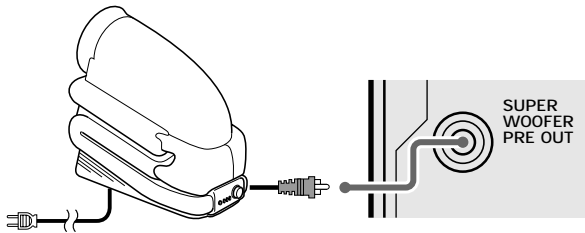

**Power cord**  
To wall AC outlet

### FM outdoor antenna

Lead the 75Ω coaxial cable connected to the FM outdoor antenna into the room and connect it to the FM 75Ω terminal.

Use a commercially-available antenna adapter (a small-sized model).

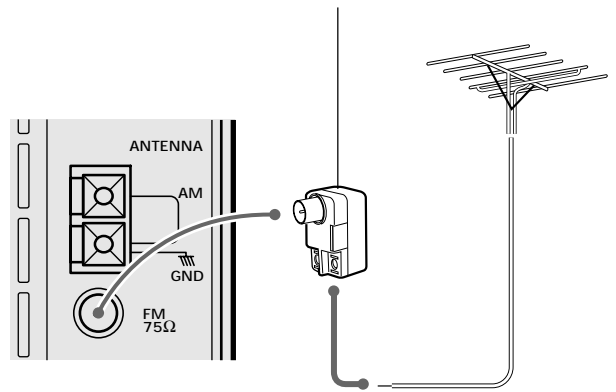

Main unit

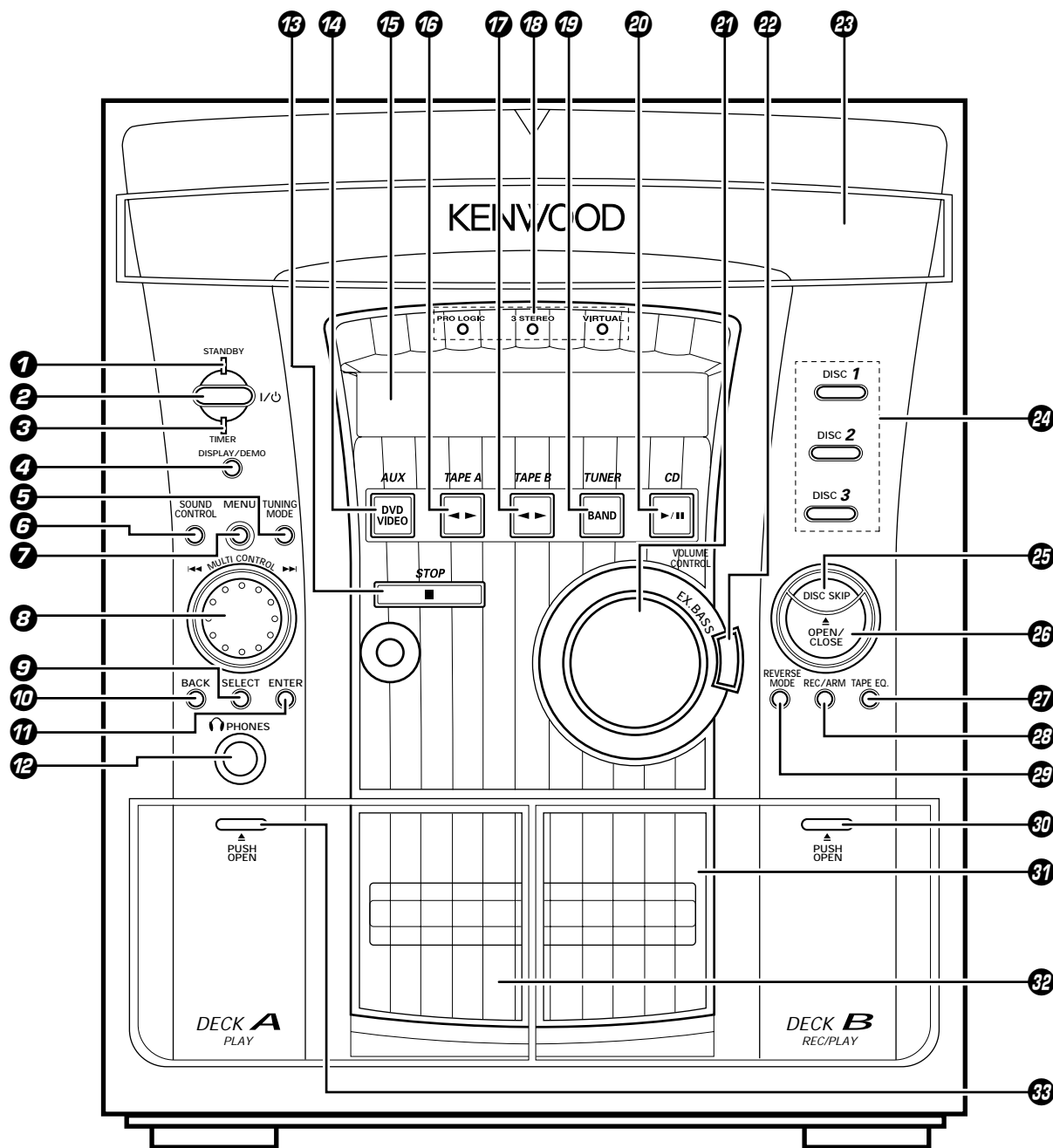

CD player unit

- 13 **STOP (■) key** → 21  
Operation key for the CD player and cassette deck.
- 20 **CD (▶/||) key** → 21  
Press to select the CD and start playback.
- 23 **Disc tray** → 20  
Three discs can be stored.
- 24 **DISC SELECTOR keys** → 21  
The disc for playback (or recording) is selected.

- ∞ **DISC SKIP key** → 21  
The disc for playback (or recording) is selected. This is also used for loading CDs onto the disc tray.
- 25 **OPEN/CLOSE (▲) key** → 20  
The disc tray is opened and closed.

Preparation section

## Receiver

- 1 STANDBY indicator** → 16  
The indicator lights up when the power is set to the STANDBY mode.
- 2 STANDBY (I / ⏻) key** → 16  
**STANDBY (POWER) key (For U.S.A. Canada)** → 16  
Power ON/OFF switching is executed.
- 3 TIMER indicator** → 55  
The indicator lights up when the power is set to the STANDBY mode after having activated a timer program.
- 4 DISPLAY/DEMO key** → 4 → 12  
Switches the displayed information.
- 5 TUNING MODE key** → 26  
Switches the tuning mode.
- 6 SOUND CONTROL key** → 46  
Used in combination with the **MULTI CONTROL** jog dial to set up the equalizer pattern, DSP play or surround play.
- 7 MENU key** → 15  
Press to switch the mode set with the **MULTI CONTROL** jog dial ON or OFF.
- 8 MULTI CONTROL (◀◀ ▶▶) jog dial** → 15 → 23 → 26  
Turn this dial to select optimum modes according to the desired operations.  
When the CD input is selected, this dial is used to skip tracks.  
When the TUNER input is selected, this dial is used to select a station.  
When the TAPE input is selected, this dial is used to fast forward or backward (rewind) the tape.

- 9 SELECT key** → 15  
Used in combination with the **MULTI CONTROL** jog dial to select or set a variety of operation modes.
- 10 BACK key** → 15  
Press when setting a mode using the **MULTI CONTROL** jog dial to return to the previous step and restart the operation from there.
- 11 ENTER key** → 15  
Press to enter or execute the mode selected with the **MULTI CONTROL** jog dial.
- 12 PHONES jack** → 18  
For connection of a headphone (optional).
- 13 STOP (■) key** → 21  
Operation key for the CD player and cassette deck.  
**When power is STANDBY:**  
Used for displaying the time. (When this key is pressed while the "TIMER" indicator is lit, the timer icon and the timer reservation setting mode appears in the display, then the display returns to the previous condition.)
- 14 AUX (DVD/VIDEO) key** → 18 → 50  
Press to select the source connected to the AUX or 6CH. INPUT jacks.
- 15 Display** → 12
- 16 Surround-related indicators** → 46
- 17 TUNER (BAND) key** → 26  
Press to select the tuner and switch the receiving band.
- 18 VOLUME CONTROL knob** → 18  
This is used for volume adjustment.
- 22 EX. BASS (Extra bass) key** → 19  
Switches the extra bass play on and off.

## Cassette deck unit

- 13 STOP (■) key** → 23  
Operation key for the CD player and cassette deck.
- 15 TAPE A (◀▶) key** → 22  
Press to select the deck A and start playback.
- 17 TAPE B (◀▶) key** → 22  
Press to select the deck B and start playback.
- 27 TAPE EQ. key** → 23  
Press to switch the Tape Equalizer on and off.
- 28 REC/ARM key** → 29  
Press to start recording. Pressing this key while recording pauses creates a non-recording space (blank) of about 4 seconds.
- 29 REVERSE MODE key** → 23 → 29  
The reverse mode of the deck (both sides, repeated, one side) is switched.
- 30 PUSH OPEN (▲) key (B)**  
Press to load or remove a tape.
- 31 B deck cassette holder**
- 32 A deck cassette holder**
- 33 PUSH OPEN (▲) key (A)**  
Press to load or remove a tape.

**Display** The displays given in this manual are approximations only. They may differ from what actually appears on the display.

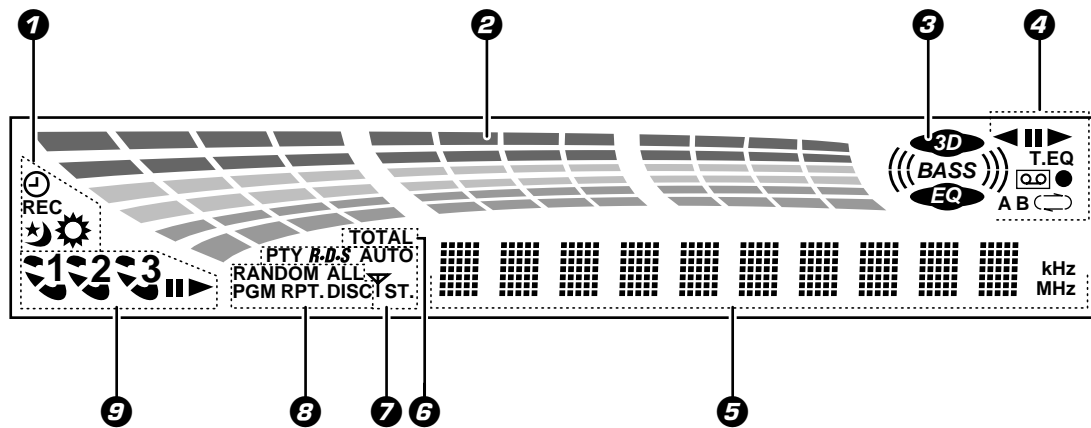

### 1 Timer-related indicators

### 2 Sound level meter

The display varies according to the music or the operations of the CD, tape, etc.

During the volume adjustment, this meter displays the current sound level as a reference.

### 3 Equalizer/EX.Bass/DSP/"S. direct" indicators

### 4 Cassette deck-related indicators

This section contains the cassette deck operation indicators. The indicated information includes the tape reverse mode and tape transport direction.

### 5 Character information display

Displays the input selection, frequency, volume level, etc.

### 6 TOTAL indicator

Light to indicate the elapsed playing time or remaining time of the entire CD.

### 7 Tuner-related indicators

### 8 REPEAT/PGM/RANDOM indicators

When repeat, program or random playback of CD is selected, the indicator lights.

### 9 CD player-related indicators

This section contains the CD play and pause mode indicators.

## Switching the sound level meter display mode

DISPLAY/DEMO



Each press switches the modes as follows.

- "Display Auto"
- "Display 1"
- "Display 2"

- ÷ When "Display Auto" is selected, the display mode during CD playback changes to "Display 1" and "Display 2" every time the track changes.
- ÷ "Display 2" is displayed regardless of the current music signal level.

## Remote control unit

The keys on the remote control unit with the same names as on the main unit have the same function as the keys on the main unit.

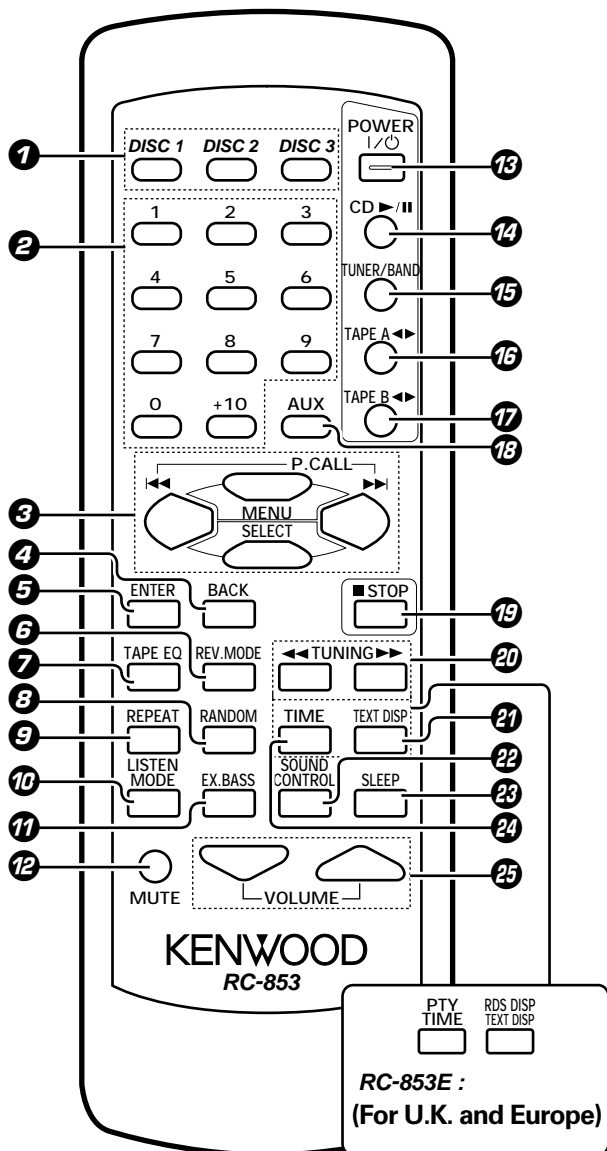

- 1 DISC SELECTOR keys** → 21  
The disc for playback (or recording) is selected.
- 2 Numeric keys** → 21  
Used as number keys when the input is CD or TUNER.
- 3 MULTI CONTROL keys** → 15 → 23 → 26  
The left and right keys have the same functions as the **MULTI CONTROL** jog dial on the main unit.
- P.CALL** (skip) keys (CD/TUNER) → 21 → 27  
When the CD input is selected, press to skip forward or backward on the disc.  
When the TUNER input is selected, press to select preset station.  
When the TAPE input is selected, press the key to fast-forward or rewind the tape.
- MENU key** → 15  
**SELECT key** → 15

- 4 BACK key** → 15
- 5 ENTER key** → 15
- 6 REV. MODE key** → 23 → 29  
The reverse mode of the deck (both sides, repeated, one side) is selected.
- 7 TAPE EQ key** → 23
- 8 RANDOM key** → 36  
For CD playback, switching is executed between random playback and normal playback.
- 9 REPEAT key** → 34  
Used for repeated playback of a CD.
- 10 LISTEN MODE key** → 46  
Press to select surround playback mode.
- 11 EX. BASS key** → 19
- 12 MUTE key** → 19  
This is used to mute the sound temporarily.
- 13 POWER (I/O) key** → 16  
Power ON/OFF switching is executed.
- 14 CD (▶/||) key** → 20
- 15 TUNER/BAND key** → 26
- 16 TAPE A (◀▶) key** → 22
- 17 TAPE B (◀▶) key** → 22
- 18 AUX key** → 18  
Press to select the source connected to the AUX or 6CH. INPUT jacks.
- 19 ■ STOP key** → 21 → 23  
Operation key for the CD player and cassette deck.
- 20 TUNING (◀◀ ▶▶) keys (CD/TAPE/TUNER)** → 21 → 23 → 26  
When the CD or TAPE input is selected, press to fast forward or backward (rewind) the disc or tape.  
When the TUNER input is selected, press to select a station.
- 21 TEXT DISP key** → 40  
Press to switch the text information recorded in a CD TEXT disc.
- RDS DISP key (For U.K. and Europe)** → 37  
The display contents are switched during reception of RDS broadcasts.
- 22 SOUND CONTROL key** → 46  
Press to select the equalizer pattern, DSP play or surround play.
- 23 SLEEP key** → 52  
Press to set the sleep timer.
- 24 TIME key** → 21  
Press to switch the time information on the CD player unit.
- PTY key (For U.K. and Europe)** ∅  
This is used to specify the program type when searching for a station.
- ∞ VOLUME keys** → 18  
This is used for volume adjustment.

**Loading batteries**

➊ Remove the cover.

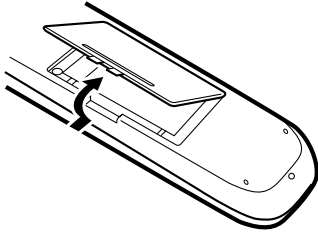

➋ Insert batteries.

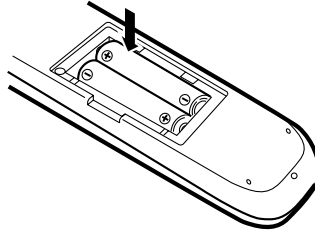

➌ Close the cover.

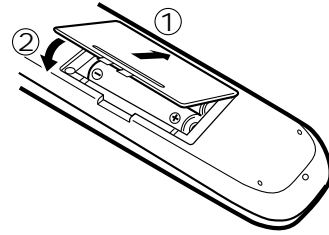

÷ Insert two R6 ("AA"-size) batteries following the polarity indications.

Preparation section

**Operation**

Plug the power cord into the mains power outlet and press the on/standby (I / ⏻ POWER) key of the remote control unit to turn power ON. After the power has been turned ON, press the desired key.

To turn power off, press the on/standby (I / ⏻ POWER) key again.

The power mode enters the STANDBY mode in which the "STANDBY" indicator lights up. (The "TIMER" indicator also lights in this mode if a timer program has been activated.)

÷ When pressing more than one remote control key successively, press the keys securely by leaving an interval of 1 second or more between the key presses.

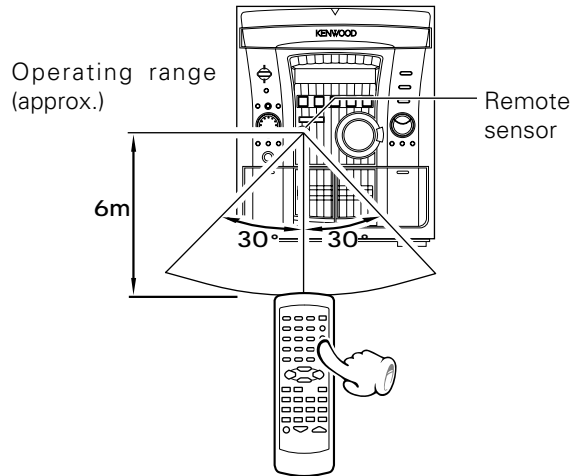

1. The provided batteries are intended for use in operation checking, and their service life may be short.
2. When the remote controllable distance becomes short, replace both of the batteries with new ones.
3. If direct sunlight or the light of a high-frequency fluorescent lamp (inverter type, etc.) is incident to the remote sensor, malfunction may occur. In such a case, change the installation position to avoid malfunction.

This unit has a jog dial named the **MULTI CONTROL** jog dial.

The **MULTI CONTROL** jog dial makes it possible to set (establish) many functions in a simple procedure.

When the **MENU** key is pressed, the items appear in the display according to the **MULTI CONTROL** jog dial operation so you can select the desired mode based on a more intuitive method.

You can also use the **◀◀ ▶▶** keys on the remote control unit instead of the **MULTI CONTROL** jog dial.

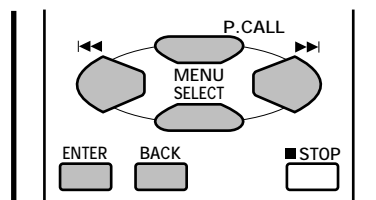
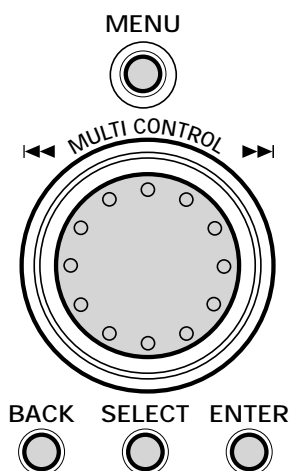

## MULTI CONTROL jog dial

- 1 Press the **MENU** key to enter the **MULTI CONTROL** setting mode.
- 2 Select an operation mode by turning the **MULTI CONTROL** jog dial or pressing the **◀◀ ▶▶** (**MULTI CONTROL**) keys on the remote control unit.
- 3 Set, establish or execute (determine) items by pressing the **SELECT** key and/or **ENTER** key.

### Display examples

The following items can be selected by turning the **MULTI CONTROL** jog dial or pressing the **◀◀ ▶▶** (**MULTI CONTROL**) keys on the remote control unit.

- "CD Program Play"
- "Recording Options"
- "Tape Dubbing"
- "Audio Options"
- "Clock Options"
- "Surround Setup"
- "Language Options"

÷ To cancel the mode for setting (using **MULTI CONTROL**), read the description of each item in this manual.

÷ Press the **BACK** key to return to the previous step and restart operation from there. (The **BACK** key is inoperative once scrolling message "Press 'ENTER' to --" has been displayed.)

÷ With the remote control unit, pressing the **MENU** key makes it possible to select the same items as those available on the main unit using the **MULTI CONTROL** keys.

**In the MULTI CONTROL setting mode, only the volume control and ■ STOP key are operative.**

This unit incorporates a clock function. Be sure to adjust to the correct time before using the timer function. The time can be displayed only while the power is off.

**1 Switching the power ON (OFF).**

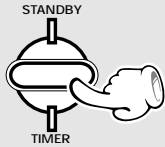

When the power is ON, pressing the STANDBY key enters the power STANDBY mode, in which the standby indicator lights up.

**2 Select "Clock Options".**

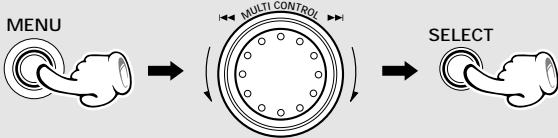

The following items can be selected by turning the MULTI CONTROL jog dial.

- "CD Program Play"
- "Recording Options"
- "Tape Dubbing"
- "Audio Options"
- "Clock Options"**
- "Surround Setup"
- "Language Options"

Clock Opti

← Scrolled display (Clock Options)

**3 Select "Adjust Time".**

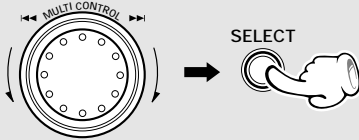

The following items can be selected by turning the MULTI CONTROL jog dial.

- "Sleep Timer"
- "Adjust Time"**
- "Timer Play"
- "Auto Power Save"

**4 Adjust the hour.**

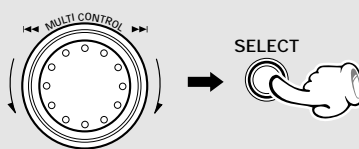

Example: Adjustment to 8:45

|   |   |
|---|---|
|   |   |
| (For U.K. and Europe)<br>0↔1↔2...13↔14...↔0 ... | (Other countries)<br>AM12↔AM1↔AM2...<br>PM1↔PM2...↔AM12 ... |

To decrease the figure      To increase the figure

÷ The time display starts to blink.  
÷ Press the **SELECT** key. The hour is entered and the minute display starts to blink.

**5 Adjust the minute.**

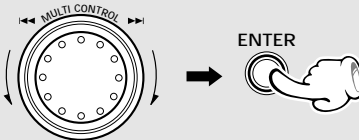

|   |                   |
|---|-------------------|
|   |                   |
| (For U.K. and Europe)<br>00↔01↔02...59↔00↔01... | (Other countries) |

To decrease the figure      To increase the figure

÷ Press the **BACK** key to return to the previous step and restart operation from there.  
÷ To adjust correct time, press the **ENTER** key at the same moment as a time announcement.

**To display the time**

(In standby mode)

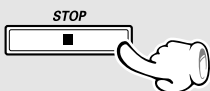

(Displayed for approx. 5 sec.)

÷ The clock display blinks after the power cord has been unplugged from the AC power outlet and plugged in again or after a power failure. In this case, set the time of the day again.



You can change the display language manually.

## 1 Select "Language Options".

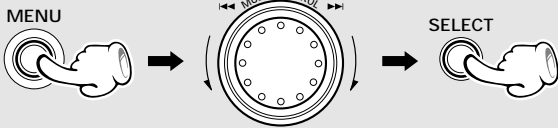

The following items can be selected by turning the MULTI CONTROL jog dial.

- "CD Program Play"
- "Recording Options"
- "Tape Dubbing"
- "Audio Options"
- "Clock Options"
- "Surround Setup"
- "Language Options"**

Language 0

← Scrolled display (Language Options)



Select Lan

← Scrolled display (Select Language)

## 2 Select the desired language.

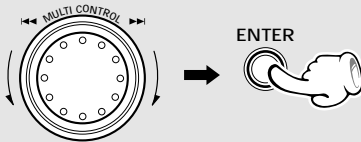

The following items can be selected by turning the MULTI CONTROL jog dial.

- "English"
- "Français" (French)
- "Deutsch" (German)
- "Español" (Spanish)
- "Italiano" (Italian)

### When you do not recognize which language is displayed:

÷ Press the **MENU** key so that the display shows "Language Options" (English), "Options de langue" (French), "Spracheinstellungen" (German), "Opción Idioma" (Spanish) or "Opzioni lingua" (Italian). Then press the **SELECT** key to open the language selection menu.

### About the beep sound

When you press the key, a beep sounds. The number of times that the beep sounds changes depending on the operation.

When a beep sounds

- Once: Normal operation
- twice: The MENU or ENTER key is pressed.
- three times: Abnormal operation (The error message appears in the display.)
- no sound: The key that cannot be operated is pressed.

You can also set the beep to OFF:

#### 1 Select "Audio Options".

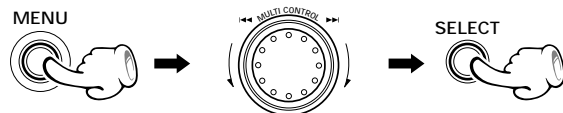

#### 2 Select "Beep sound".

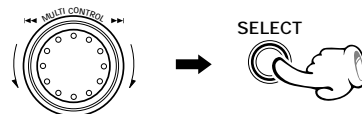

#### 3 Select "Beep on" or "Beep off".

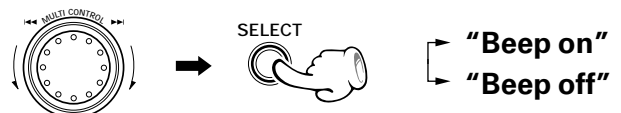

## Basic operation

**Listening through headphones**  
 Insert the headphone plug into the **PHONES** jack.  
 ÷ The sounds from all speakers are cut off.

**Muting the sound temporarily (MUTE)**

**Reproducing sound with enhanced bass (EX.BASS)**

**Reproducing sound with enhanced bass (EX.BASS)**

Basic section

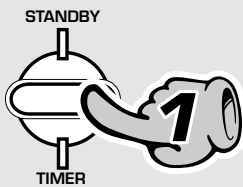

### 1. Switching the power ON (OFF)

When the power is ON, pressing the **STANDBY** key enters the power **STANDBY** mode, in which the standby indicator lights up.

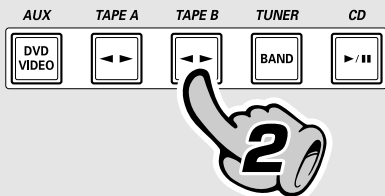

### 2. Selecting the desired output

Select the desired source by pressing the **AUX (DVD/VIDEO)**, **TAPE A**, **TAPE B**, **TUNER**, or **CD** key.

- ÷ When you press the **TAPE A**, **TAPE B**, or **CD** key, the unit starts playback automatically.
- ÷ If you select the **AUX (DVD/VIDEO)** (external input) mode, also read the instruction manual of the component connected to the **AUX** or **6CH. INPUT** jacks.

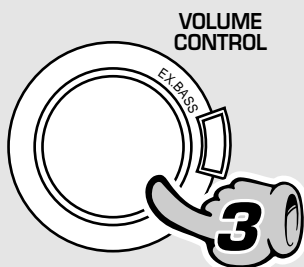

### 3. Volume adjustment

- ÷ The display shows a reference value. (The reference value is also shown visually by the sound level meter.)

### Muting the sound temporarily (Remote control unit only)

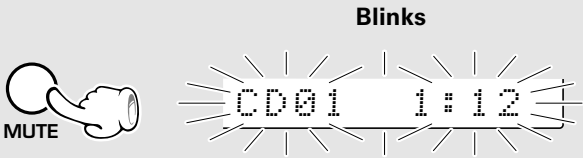

÷ Press again to resume the original volume.  
÷ The sound muting is also canceled when the volume is controlled.

### Reproducing sound with enhanced bass (EX. BASS)

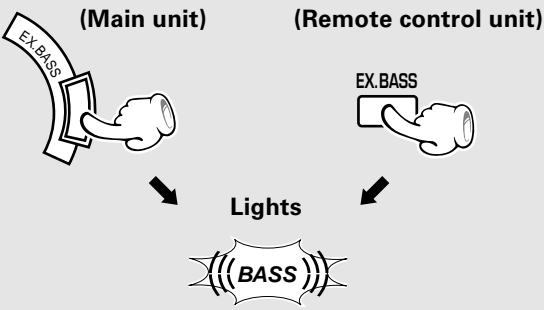

÷ Each press switches EX.BASS on and off alternately.  
÷ EX.BASS cannot be activated when the selected input is "6ch.Input".

When CD has been selected.

CD01 0:00

Volume 19

Volume display

### One-touch operation function

The power can also be turned ON by pressing the TAPE A, TAPE B, TUNER, or CD key. It is also possible to turn the power ON by simply pressing the OPEN/CLOSE (▲) key.

÷ When the CD or TAPE input is selected and a disc has been loaded in the disc tray or a tape has been loaded in the deck for use in playback, playback starts automatically.

### Standby mode

While the "STANDBY" indicator of the unit is lit, a small amount of current is flowing into the unit to back up its internal memory. (The TIMER indicator also lights if a timer program has been activated before entering the STANDBY mode.)

This condition is referred to as the standby mode of the unit. While the unit is in the standby mode, it can be turned ON from the remote control unit.

This unit has been designed to minimize power consumption.

# Playback of CD



If a disc has already been loaded in the CD player and the power is OFF, simply pressing the CD key turns power automatically ON and starts playback.

Playback from desired track (DISC 1 – 3, Numeric keys)

Start playback/  
To pause playback  
(CD ►/II)

To stop Playback (STOP ■)

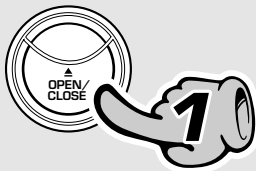
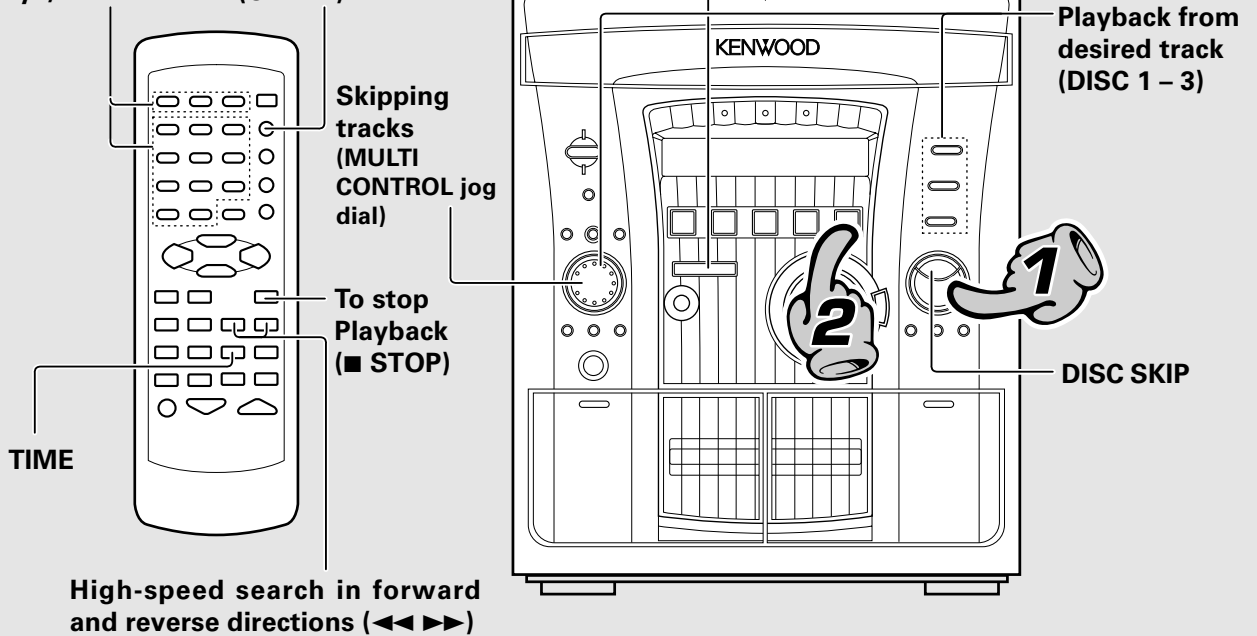

The tray opens when the key is pressed and closes when the key is pressed again.

## 1. Load discs.

- ① Open the tray.
- ② Place discs.
- ③ Close the tray.

Disc played first when the CD ►/II key is pressed.

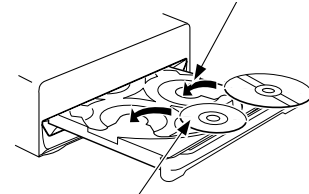

The label must be on top.

## 2. Start playback.

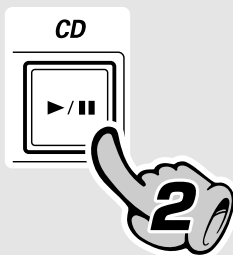

- ÷ After a few seconds, play starts from track No.1.
- ÷ Playback stops after having played all discs in the trays. (Relay play)
- ÷ When the **OPEN/CLOSE** (▲) key is pressed during playback, the tray opens but the playback continues. (The **DISC SKIP** key is inoperative at this time.)

### Skipping tracks

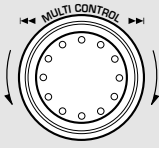
**To skip backward**  **To skip forward**

÷ The tracks in the direction the dial is rotated are skipped, and the selected track will be played from the beginning.  
 ÷ When the jog dial is rotated a little in the direction of counterclockwise once during playback, the track being played will be played from the beginning.  
 ÷ The CD tracks can also be skipped using the **⏮** **⏭** key of the remote control unit.

### High-speed search in forward and reverse directions (Remote control unit only)

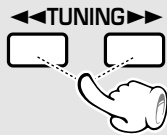
**Backward search**  **Forward search**

÷ Playback starts from the position where the key is released.

- ÷ Do not touch the playing side of disc.
- ÷ Rotate the tray with the **DISC SKIP** key to insert the third disc.
- ÷ The tray containing the disc to be played should come to the front position when the unit is seen from the front.

The selected disc is indicated.

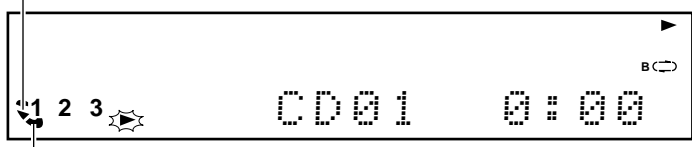

Lights when a disc is inserted at the time of playback.

### Playback from desired track

**Select the disc**

**(Main unit)**

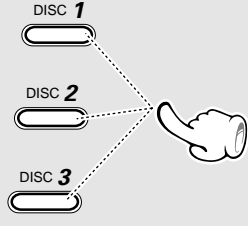

**(Remote control unit)**

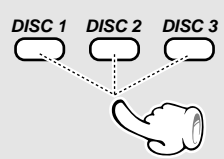

**Select the desired track No.**

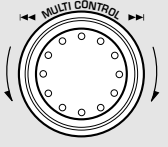
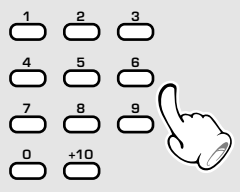
**Press the numeric keys as shown below....**

To select track No. 23: **+10** **+10** **3**

To select track No. 40: **+10** **+10** **+10** **+10** **0**

### To pause playback



÷ Each press pauses and plays the CD alternately.

### To stop playback

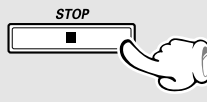

### Time display on the CD player

Each press of the **TIME** key of the remote control unit switches the displayed time information.

- ① 1 : 12 Elapsed time of track being played
- ② - 4 : 18 Remaining time of track being played
- ③ 12 : 46 Elapsed time of disc ("TOTAL" lights up)
- ④ - 63 : 14 Remaining time of disc ("TOTAL" lights up)

÷ Only the elapsed and remaining time of the track being played is displayed during program playback, random playback and single-track repeated playback.

# Tape playback



When the power is off:

By loading a tape in the cassette deck to be used in playback beforehand, simply pressing the play key automatically turns the power ON and starts playback.

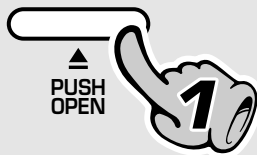
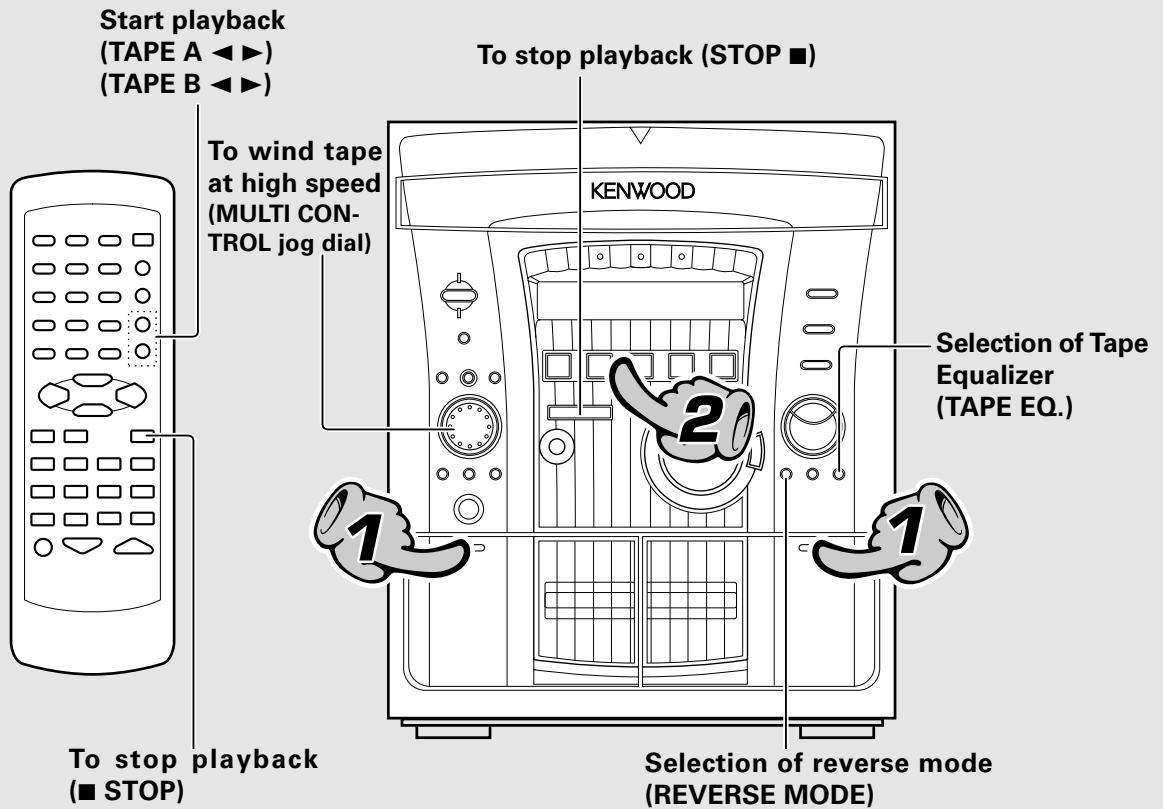

## 1. Load a cassette tape.

- ① Open the cassette holder.
- ② Insert a tape and close the door.

÷ Since tapes that are longer than 100 minutes are very thin, the tape could adhere to the pinch roller or be easily cut. It is recommended that these tapes not be used with this unit to prevent possible damage.



## 2. Select the deck to be used for playback.

The selected deck (A or B) starts playback.

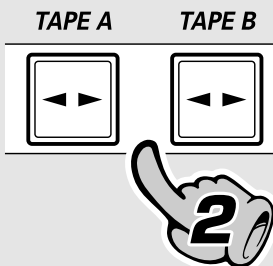

÷ Each time you press the TAPE A or TAPE B key, the direction changes.

### To wind tape at high speed

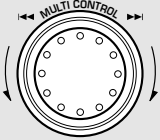

To fast wind in direction ←

To fast wind in direction →

÷ Press the ■ key to stop fast winding.

### Selection of reverse mode



**REVERSE MODE**

Each press switches the modes as follows.

- ① "↔" .... Playback stops after having played both sides of tape in a deck. (Relay play : → 24)
- ② "↺" ... Endless playback of both sides of tape.
- ③ "↻" ..... Playback stops after having played one side of tape.

### Selection of Tape Equalizer

Select Tape Equalizer only when playing back a tape recorded with Dolby Noise Reduction. (A tape recorded without Dolby NR cannot be reproduced in normal audio if Tape Equalizer is selected when playing it.)



Lights up when Tape Equalizer is on.



Each press switches the modes as follows.

- ① "T.EQ" ON ..... Tape Equalizer is used
- ② "T.EQ" OFF ..... Tape Equalizer is not used

÷ The Tape Equalizer is effective for reduction of higher-frequency noise.

### To stop playback

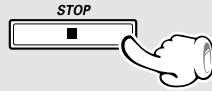

÷ Do not take out the cassette tape until the tape transport has stopped completely.

- ÷ Normal (TYPE I) or high (TYPE II) tape selection is set automatically.
- ÷ Remove tape slack before loading.
- ÷ Close the door securely.

Lights up when a tape is present in the deck in use.

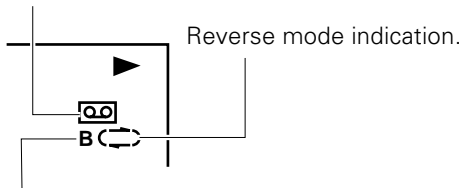

Displays the selected deck.

- ÷ If the tape transport direction is opposite to the desired direction, press the play key corresponding to this.

### Transport direction indicators

The indicators (◀▶) indicate the current direction in which the tape advances when playback or recording is started automatically by the one-touch operation function, etc. This direction is the direction stored in memory when the tape was last stopped.

(To switch the tape transport direction, press the play key corresponding to the desired direction then press the stop (■) key.)

Tape direction indicators of currently selected deck.

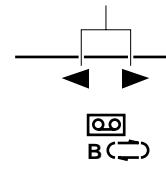

### **Relay play**

When tapes are set in the decks A and B and the reverse mode is set to "↔" (play of both sides), play of the second deck will be started automatically after play of the first deck has been completed. Tape play will be repeated alternately.

- ÷ Relay play is not possible in the reverse modes "↔" and "↔".
- ÷ If a tape is loaded only in either deck, playback stops after having played both sides of the tape.

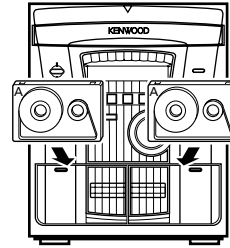

### **A tip for the use of the tape counter**

The tape counter is set to "0000" when a cassette tape is loaded. In case you want to interrupt recording (playback) in the middle of the tape, the counter reading will be helpful as a reference for locating the same position when continuing the recording (playback) the next time. The tape counter figure decrements during recording or playback of the reverse side (while the ◀ tape transport indicator is lit).

To set the tape counter to "0000", open the cassette holder once. Then the counter will be reset.

TAPE 0000



# CHANNEL SPACE setting *(Except for the U.S.A., Canada, U.K., Europe, and Australia)*

The space between radio channels has been set to the one that prevails in the area to which the system is shipped. However, if the current channel space setting does not match the setting in the area where the system is to be used, for instance when you move from area 1 or area 2 shown in the following table or vice versa, proper reception of AM/FM broadcasts cannot be expected. In this case, change the channel space setting in accordance with your area by referring to the following table.

| Area                                       | CHANNEL SPACE freq.         |
|--|-----------------------------|
| ① USA, Canada and South American countries | FM : 100 kHz<br>AM : 10 kHz |
| ② Other countries                          | FM : 50 kHz<br>AM : 9 kHz   |

- ➊ Select the TUNER input.
- ➋ While holding the TUNER (BAND) key depressed, turn the MULTI CONTROL jog dial to select the system mode.



- ➌ ① "FM100/AM10 kHz" STEP,
- ➍ ② "FM 50 /AM 9 kHz" STEP,

FM100/AM10 kHz → FM 50/AM 9 kHz

÷ The "AM" display is variable depending on the model (country or area), and "MW" may be displayed in some areas.

## Receiving broadcast station

It is also possible to receive them by one-touch operations.



When the TUNER/BAND key is pressed, this unit will be switched on automatically and tuned to the last received frequency.

### Collective presetting of stations (TUNING MODE)

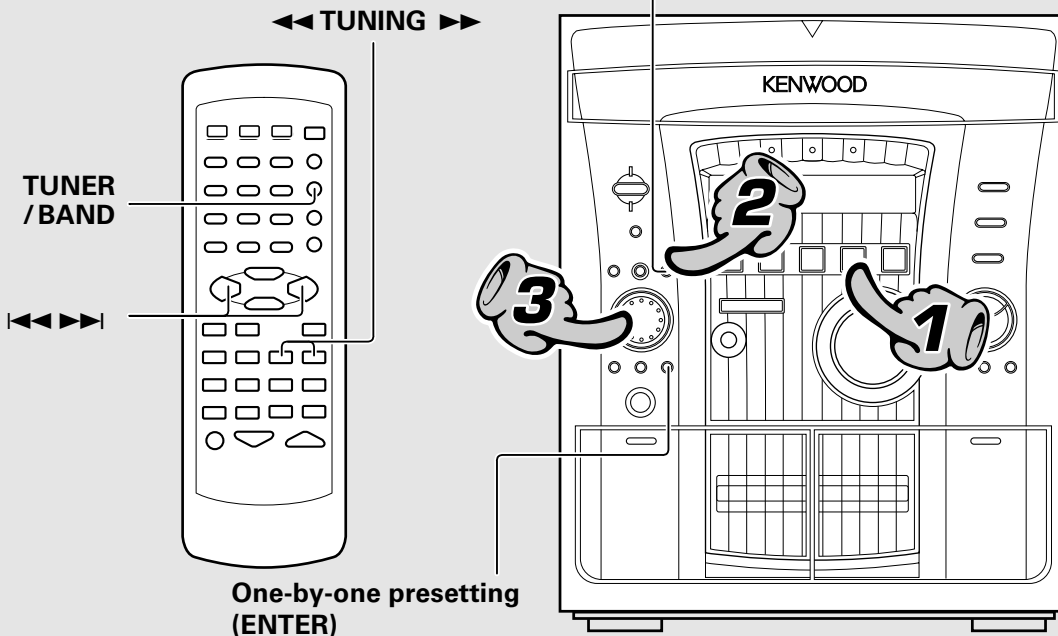

One-by-one presetting (ENTER)

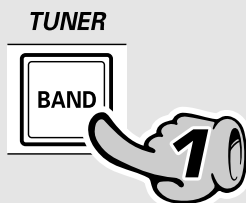

### 1. Select the broadcast band.

Each press changes the band.

- |      |    |           |
|------|----|-----------|
| ① FM | or | ① FM      |
| ② AM |    | ② MW (AM) |
|      |    | ③ LW      |

÷The broadcast bands defer depending on the model (country or area).

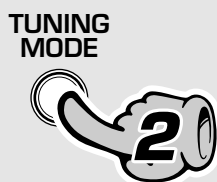

### 2. Selecting the tuning mode

Each press alternates the mode.

- “Auto” (Auto tuning)
- “P.call” (Preset call)
- “Manual” (Manual tuning)

÷ When no operation has been performed for 5 seconds while “P.call” is displayed, the tuning mode is set automatically to the “Auto” mode.

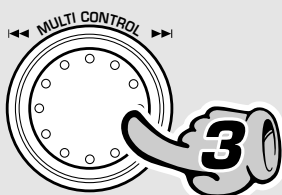

### 3. Select a station.

#### When no stations have been memorized

- Auto tuning** : Turn the **MULTI CONTROL** jog dial to receive the next tuned station automatically.  
(On the remote control unit, press the ◀▶▶▶ key.)
- Manual tuning** : Turn the **MULTI CONTROL** jog dial to select a frequency.  
(On the remote control unit, press the ◀▶▶▶ key.)

### Collective presetting of stations (Auto memory)

Keep the TUNING MODE key depressed (about 2 seconds).

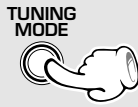

(For U.K. and Europe)

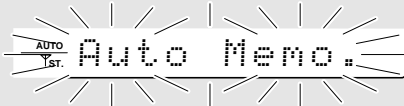

(Other countries)



÷ Some stations may not be able to be preset if their reception conditions are weak.

- ÷ A maximum of 30 stations are preset automatically by giving the priority to the FM band.
- ÷ When there are many stations and the intended station has not been preset, please use **"One-by-one presetting (manual preset)"**.
- ÷ The stations which have been preset are overwritten.

Example when an FM station is received



- ÷ Use the manual tuning mode when reception is noisy due to weak reception. (In the manual mode, stereo broadcasts are received in monaural.)
- ÷ Normally, use the **"Auto"** (Auto tuning) mode.
- ÷ If you are operating the remote control unit, the **"Auto"** (Auto tuning) and manual tuning mode can be alternated by pressing the stop (■) key (Remote).

#### When stations have been memorized (Preset call)

Turn the MULTI CONTROL jog dial to select a station.  
(On the remote control unit, press the ◀▶▶▶ key.)

- ÷ When a key is held depressed, preset stations will be skipped at an interval of about 0.5 second.
- ÷ Preset stations can also be recalled using the numeric keys of the remote control unit.

### One-by-one presetting (manual preset)

① Press the ENTER key during reception.



Presetting is cancelled when no operation is executed for 5 seconds or more.

② Select one of the preset numbers from 1 to 30.

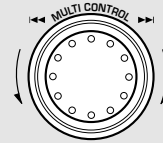

Presetting is cancelled when no operation is executed for 5 seconds or more.

③ Press the ENTER key again.



- ÷ Repeat steps ①②③ to preset other stations.
- ÷ If several stations are preset under the same number, the previous memory is replaced with the latest memory contents.

Lights during auto tuning

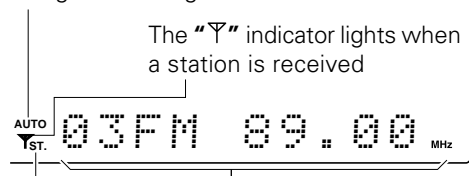

Lights during stereo reception

Frequency display

# Recording on TAPE



Note that this cassette deck cannot record onto Metal tapes.

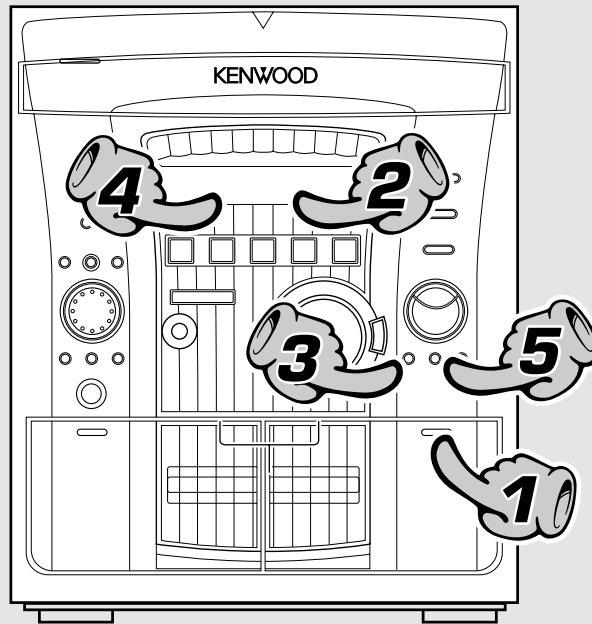

Basic section

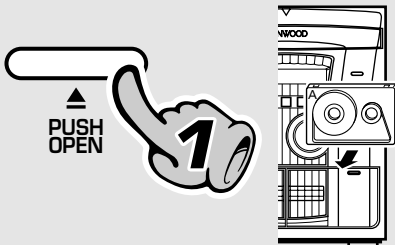

## 1. Load a cassette tape. (Recording is available on deck B only.)

- ❶ Open the cassette holder of deck B.
- ❷ Insert a tape.
- ❸ Close the door.

÷ Differentiation between normal (TYPE I) and high (TYPE II) tape is set automatically.  
 ÷ Remove tape slack before loading.

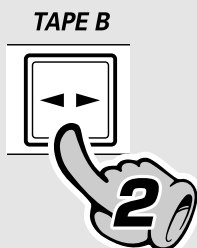

## 2. Select the tape transport direction.

To reverse the transport direction

- ❶ Select deck B by pressing the TAPE B key.
- ❷ Press the TAPE B key so that the desired direction indicator appears. → 23
- ❸ Stop playback (by pressing the ■ key).

÷ When recording is started, the tape is transported in the direction selected in this step.  
 ÷ Wind the tape to the position where recording is to be started.

REVERSE MODE



## 3. Set the recording condition.

Select the reverse mode.

→ 29

÷ The Tape Equalizer cannot be used in recording.

### To pause recording (Main unit only)

REC/ARM



Lights

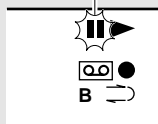

- ÷ Pressing the key pauses recording after leaving a non-recorded space of about 4 seconds.
- ÷ If the key is pressed again in less than 4 seconds after it has been pressed, recording resumes from that instant.

### Selection of the reverse mode

REVERSE MODE



Each press switches the modes as follows.

- ① "↔" .... Recording stops after having recorded both sides of tape.
- ② "⇄" ... Recording stops after having recorded both sides of tape.
- ③ "↔" ..... Recording stops after having recorded one side of tape.

- ÷ When the "◀" transport direction indicator is lit, recording always stops after having recorded one side of tape.

Select an input source other than "TAPE A or B".



## 4. Select the source to be recorded.

Press the desired key.

CD01 1:12

The input source component to be recorded should be displayed.

- ÷ If a disc has already been loaded when the CD input is selected, it will start to play automatically. In this case, press the stop (■) key to stop it.
- ÷ When you select DVD/VIDEO (External input), adjust the input level. → 45

## 5. Start recording.

REC/ARM



- ① Start recording.
- ② Play (or tune) the input source to be recorded.

Lights

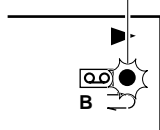

- ÷ If a disc has already been loaded when the CD input is selected, it will start recording automatically.
- ÷ Even if deck A is selected, it is automatically switched to deck B at the start of recording.
- ÷ Recording stops automatically when the tape side(s) to be recorded have been fully recorded.
- ÷ Press the stop (■) key of the cassette deck unit to stop recording (see the next page).

### **Tips in CD recording**

When recording CD tracks onto a tape, if you leave the cassette deck in record-pause mode beforehand, the cassette deck recording can be started at the same time as the CD starts to be played (synchronous recording function).

- ① Set the CD player in pause mode.
- ② Select the track to be recorded with the |◀◀ ▶▶| keys.  
(The CD player pauses at the beginning of the selected track.)
- ③ Put the cassette deck in Record-pause mode.  
(Press the REC/ARM key twice.)
- ④ Start playing the CD.  
(Synchronous recording starts.)

÷ Recording stops when the stop (■) key of the CD player is pressed. To stop the CD playback, press the stop (■) key again.

### **Beat cancel function (For U.K.)**

There may be cases in which beat noise interferes with recording of AM(MW)/ LW broadcasting. In such a case, press the TAPE EQ. key during recording to reduce or suppress the beat noise.



←Scrolled display (Beat cancel)

Beat cancel

## Copying tape (Tape dubbing)

The contents of the tape in deck A can be copied onto the tape in deck B.

### Load tapes in the decks.

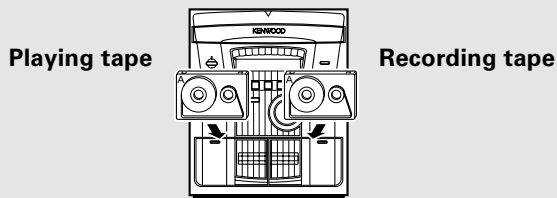

- 1 Select "↔" (double-side recording) or "→" (one-side recording). 



- 2 Select "Tape Dubbing".

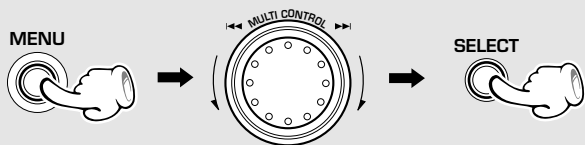

The following items can be selected by turning the MULTI CONTROL jog dial.

- "CD Program Play"
- "Recording Options"
- **"Tape Dubbing"**
- "Audio Options"
- "Clock Options"
- "Surround Setup"
- "Language Options"

← Scrolled display (Tape Dubbing)

Tape Dubbi

- 3 Use the same tape transport directions.

÷ When recording is started, the tape will be transported in the direction selected in this step.

(  : side A,  : side B)

- (1) Select the transport direction of deck A.

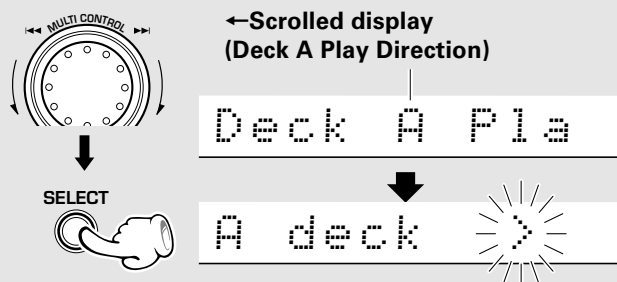

- (2) Select the transport direction of deck B.

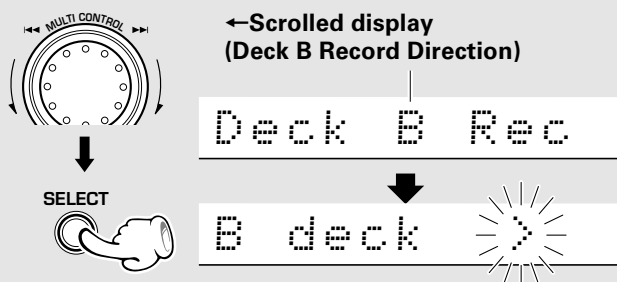

- 4 Start dubbing.

← Scrolled display (Press 'ENTER' to Start)

Press 'ENT



÷ Dubbing ends automatically when the side(s) to be dubbed has been fully recorded on.

### To stop dubbing



÷ The deck B will stop after creating a non-recorded portion of about 4 sec, and then the deck A will stop.

÷ Dubbing can also be stopped by pressing the stop (■) key of the cassette deck unit. Note that the non-recorded space is not created in this case.

The TAPE EQ. key is ineffective during dubbing.

## Listening in the desired sequence (program playback)

Any titles on the discs in the tray can be listened to in the desired sequence. (Max. 32 titles)

Select the "CD" input.

### 1 Check that the CD player is in the stop mode.

If it is in play mode

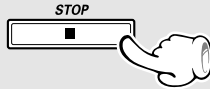

### 2 Select "CD Program Play".

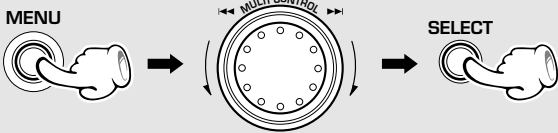

### 3 Enter track No.s in the order you want to play them.

#### 1 Select the disc.

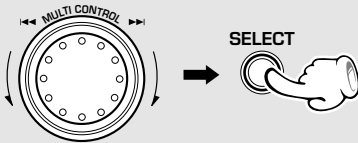

#### 2 Select the track.

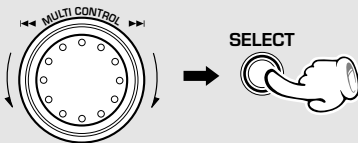

(To select other tracks, repeat steps 1 and 2 for each of the additional tracks.)

#### 3 Press the ENTER key.



(Go to step 4 if you do not need to check the program contents.)

÷ If the operation in step 2 is performed during playback of a track, the current track can be programmed as the first track in the program.

The following items can be selected by turning the MULTI CONTROL jog dial.

"CD Program Play"

"Recording Options"

"Tape Dubbing"

"Audio Options"

"Clock Options"

"Surround Setup"

"Language Options"

CD Program

←Scrolled display (CD Program Play)

←Scrolled display (Select Disc/Track No.)

Select Dis

Lights



P01 D1 T??

P01 D1 T01

÷ Even if you program a disc or track which does not exist in the tray, it is deleted automatically in playback.

÷ Press the **BACK** key to return to the previous step and restart operation from there.

÷ Up to 32 tracks can be programmed. When "Full" is displayed, no more tracks can be programmed.

←Scrolled display

(Press 'ENTER' to Start, 'JOG' to Check )

Press 'ENT



#### 4 Check the programmed tracks (and replace, add or delete tracks as required).

To check:

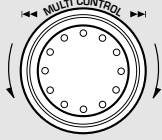

#### To replace a track in the program:



1 Select the programmed disc or track to be replaced and press the SELECT key.

SELECT



2 Select a disc or track to replace the disc or track selected above (step 3-1 and 2).

#### To add a track to the program:



1 Select the display as shown on the right and press the SELECT key.

SELECT



2 Perform the same operations as in step 3-1 and 2.

#### To delete a track from the program:

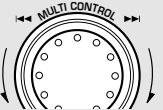

1 Select the programmed disc or track to be cleared and press the SELECT key.

SELECT



2 Select "clear" and press the SELECT key.

#### 5 Enter it.

ENTER



(Playback starts from the first programmed track (program No. 1))

- ÷ Turn the **MULTI CONTROL** jog dial during program playback to stop to the previous or next programmed track.
- ÷ When the jog dial is rotated a little in the counterclockwise direction once during playback, the track being played will be played from the beginning.
- ÷ To check (modify, add or delete) the programmed tracks after playback, perform the operations in steps 2 and 4.

Press the **TIME** key on the remote control unit to switch the time display.

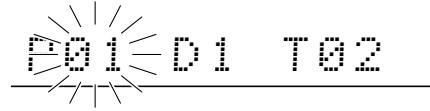

÷ The programmed tracks are displayed in sequence.



÷ The blinking item can be replaced.

Display when 12 tracks have been programmed



÷ The added track number is added to the end of the existing program.



#### To quit the program mode

1 Select "CD Program Play".

MENU



MULTI CONTROL

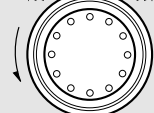

SELECT



2 Press the MENU key.

MENU



Goes off

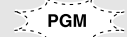

- ÷ If the key is pressed during playback, normal playback in order of tracks resumes from the current track.
- ÷ The program mode can also be canceled by pressing the **OPEN/CLOSE** (▲) key.

# Repeated playback

Desired titles or discs can be played back repeatedly.

Select the "CD" input.

## To repeat only one track

### 1 Cancel "PGM".

If the "PGM" indicator is lit, make sure to turn it off.



Goes off



### 2 Select the disc.

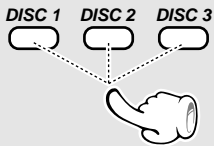

### 3 Select the track.

(Main unit)

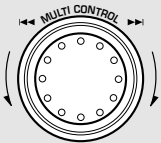

(Remote control unit)

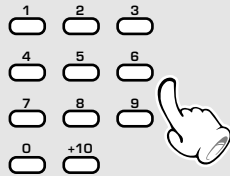

### 4 Select "One Track Repeat".

(Remote control unit only)



Press the key repeatedly to switch the display.

- ① "One Track Repeat"
- ② "Disc Repeat"
- ③ "All Repeat"
- ④ "Repeat off" (Repeat canceled)

← Scrolled display (One Track Repeat)

Lights



One Track

## To repeat a disc

### 1 Cancel "PGM".

If the "PGM" indicator is lit, make sure to turn it off.



Goes off

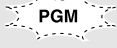

### 2 Select the disc.

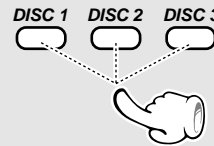

### 3 Select "Disc Repeat".

(Remote control unit only)



Press the key repeatedly to switch the display.

- ① "One Track Repeat"
- ② "Disc Repeat"
- ③ "All Repeat"
- ④ "Repeat off" (Repeat canceled)

← Scrolled display (Disc Repeat)

Lights



Disc Repea

## To stop repeated playback

Press the REPEAT key repeatedly until the repeat mode is switched off.

÷ The repeat mode can also be canceled by pressing the OPEN/CLOSE (▲) key.

### To repeat all discs

#### 1 Cancel "PGM".

If the "PGM" indicator is lit, make sure to turn it off.



Goes off



#### 2 Select the disc to be played first.

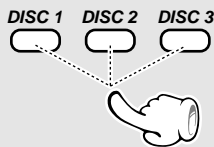

#### 3 Select "All Repeat".

(Remote control unit only)



Press the key repeatedly to switch the display.

- ① "One Track Repeat"
- ② "Disc Repeat"
- ③ "All Repeat"
- ④ "Repeat off" (Repeat canceled)

←Scrolled display (All Repeat)



Lights



### To repeat only the programmed tracks

#### 1 Perform the procedure in "Listening in the desired sequence (program playback)" till step 3 to program the desired CD tracks.



Lights



÷ All of the programmed tracks will be played repeatedly.

#### 2 Start playback.

ENTER



#### 3 Select "PGM Repeat".

(Remote control unit only)

REPEAT



Press the key repeatedly to switch the display.

- ① "PGM Repeat"
- ② "Repeat off" (Repeat canceled)

←Scrolled display (PGM Repeat)



Lights



### To stop repeated playback

Press the REPEAT key repeatedly until the repeat mode is switched off.

÷ The repeat mode can also be canceled by pressing the OPEN/CLOSE (▲) key.

# Random playback

As the titles are selected randomly each time, the music can be enjoyed of it. Random playback can play tracks in one to three discs.

Select the "CD" input.

## 1 Cancel "PGM".

## 2 Select the RANDOM mode.

(For "One Disc Random" playback, select the disc in advance.)

(Remote control unit only)



Goes off



If the "PGM" indicator is lit, make sure to turn it off. → 33

Press the key repeatedly to switch the display.

- ① "One Disc Random"  
Random play of one disc
- ② "All Disc Random"  
Random play of all discs
- ③ "Random off" (Normal playback)

Random play of one disc

←Scrolled display (One Disc Random)

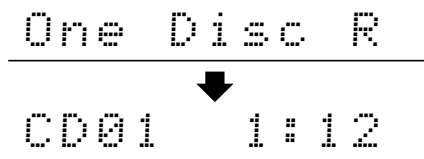

Random play of all discs

←Scrolled display (All Disc Random)

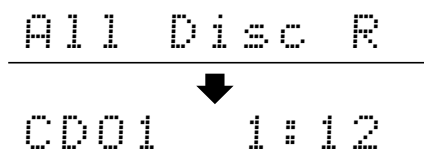

- ÷ Playback stops after each title has been played once.
- ÷ When the **TIME** key of the remote is pressed during random playback, the elapsed time and remaining time of the track being played can be displayed alternately by each press.

### To select another track in the middle of playing one

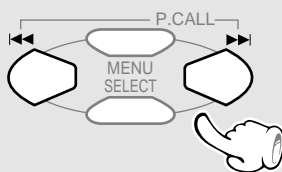

÷ Pressing the **⏮** key once returns to the beginning of the track being played.

### To repeat random playback

Select "Random Repeat".

(Remote control unit only)



Each press switches the modes as follows.

- ① "Random Repeat" ..... Random repeat mode
- ② "Repeat off" ..... Repeat canceled

### To cancel random playback

Select "Random off".

(Remote control unit only)



÷ The displayed character information returned to normal display and normal playback in order of track numbers starts from the track being played.

RDS is a system which transmits useful information (digital data) for FM broadcasts together with the broadcast signal. Tuners and receivers designed for RDS reception can extract the information from the broadcast signal for use with various functions such as automatic display of the station name.

## ***This unit is equipped with the following functions utilizing RDS data:***

### **PTY (Program Type) Search :**

The tuner automatically searches for a station which is currently broadcasting a specified program type (genre).

The "RDS" indicator lights up when an RDS broadcast (signal) is received.



### **PS (Program Service) Display :** (See below.)

When an RDS broadcast is received, the station name is automatically displayed.

÷ Some functions may not be provided or be given different names depending on countries or areas.

## ***Note before the use of RDS***

For reception of RDS stations, the auto presetting function must be used to preset the stations. With the auto memory function, RDS stations are preset with priority.

***Set the receiving band to FM and preset RDS stations with the auto memory function.***



## ***To switch the display contents***

Pressing the RDS DISP key changes the display contents.

(Remote control unit only)



### **Display mode priority ranking**

**When an RDS broadcast is received :**

#### ① **PS (Program Service) Display :**

When an RDS broadcast is received, the station name is automatically displayed.

If it is not an RDS broadcast, "No PS" is displayed.

#### ② **Frequency Display :**

The frequency of the current station is displayed.

## Searching for a desired program type (PTY search)

By specifying the type of program (genre) you want to listen to, the tuner automatically searches for a station which is currently broadcasting a program of the specified type.

Set the reception band to FM. Preset RDS stations with the auto memory function.



### 1 Select the PTY search mode.

(Remote control unit only)

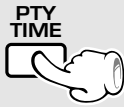

### 2 Select the desired program type.

Use program type table on the right for your convenience.

To select using the ◀◀ ▶▶ keys

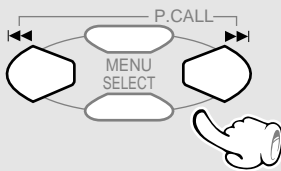

Select while "PTY" is lit.

The ◀◀ ▶▶ keys can be used to select one of the 29 program types by displaying them in sequence.

Press and hold the key and release it when the desired program type appears.

PTY-RDS AUTO ST. NEWS

÷ When an RDS broadcast is received, the program type is shown on the display. If the station is not an RDS station, "None" is displayed.

÷ "No Data" is displayed if this operation is attempted before performing the RDS auto memory function.

Program type table

| ◀◀ ▶▶ keys | Program Type Name    | Display  |
|------------|----------------------|----------|
|            | Pop Music            | POP M    |
|            | Rock Music           | ROCK M   |
|            | Easy Listening Music | EASY M   |
|            | Light classical      | LIGHT M  |
|            | Serious classical    | CLASSICS |
|            | Other Music          | OTHER M  |
|            | News                 | NEWS     |
|            | Current Affairs      | AFFAIRS  |
|            | Information          | INFO     |
|            | Sport                | SPORT    |
|            | Education            | EDUCATE  |
|            | Drama                | DRAMA    |
|            | Culture              | CULTURE  |
|            | Science              | SCIENCE  |
|            | Varied               | VARIED   |
|            | Weather              | WEATHER  |
|            | Finance              | FINANCE  |
|            | Children's program   | CHILDREN |
|            | Social Affairs       | SOCIAL   |
|            | Religion             | RELIGION |
|            | Phone In             | PHONE IN |
|            | Travel               | TRAVEL   |
|            | Leisure              | LEISURE  |
|            | Jazz Music           | JAZZ     |
|            | Country Music        | COUNTRY  |
|            | National Music       | NATION M |
|            | Oldies Music         | OLDIES   |
|            | Folk Music           | FOLK M   |
|            | Documentary          | DOCUMENT |
|            | Alarm Test*          | TEST     |
|            | Alarm*               | ALARM    |

\* This item appears only when the unit receives the data. You cannot select it using the ◀◀ ▶▶ keys.

### 3 Start the search.

(Remote control unit only)



(Press the key again during search to cancel it.)

- ÷ No sound is heard while "PTY" is blinking.
- ÷ If a program of the desired type cannot be found, "No Program" is displayed (blinking), then after several seconds the display returns to the original display.
- ÷ If a program of the desired type is found, that program is received and the program type name display changes temporarily to the frequency display, and then to the station name display.

#### To change to a different program type :

Repeat steps 1, 2, 3.

#### When searching for a Rock Music broadcast

##### Display while the tuner is searching.

Program type name display.



##### When a station is received.

Station name display.

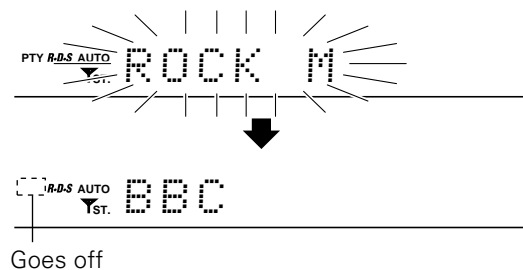

## Selection of the recording type

With this unit, the following edit recording is possible according to the purpose.



Note that this cassette deck cannot record onto Metal tapes.

### If you want to select the track to be recorded while playing a CD

#### Recording only desired titles

→ 41

#### CD ONE TRACK RECORDING



Perform this operation when a track you want to record starts during CD playback. This starts recording of the track from the beginning.

### If you want to record a CD in order of track numbers

#### Recording of an entire CD

→ 42

#### CD DIRECT RECORDING



Perform the "CD DIRECT RECORDING" operation while the CD player is in stop mode to start recording.

### If you want to record only the desired tracks

#### Recording the programmed titles

→ 43

#### CD PROGRAM RECORDING



Program the desired tracks from up to 3 CD discs in the desired order and record the programmed playback onto tape.



The recording will be interrupted for the part of the guide tape during both -side recording. To avoid the case like this, please use single-side recording.

### Regarding CD-TEXT (Remote control unit only)

When a CD-TEXT disc is played on this unit, it displays the text information (disc or track title) recorded into the CD.

To switch the displayed text information between the disc title and track title during playback, press the TEXT DISP key.

(When pressed during playback)



or



Scrolls the disc title display.

World Musi

CD player's time display.

CD01 1:12

Scrolls the track title display.

New York: B



# Recording only desired titles (CD ONE TRACK RECORDING)

At the time of CD playback, any desired title can be selected immediately for recording.



When the equalizer or other effects are applied to the sound, the effect applied to the sound can be recorded. → 46

Recording preparations are required. → 28 (Steps 1 to 3)

## 1 Playback of CD.

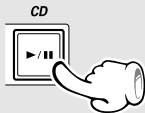

## 2 Select "Recording Options".

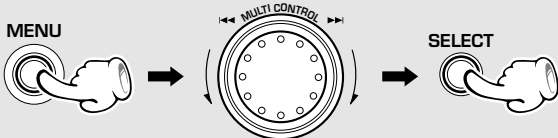

## 3 Select "CD-One Track Recording".

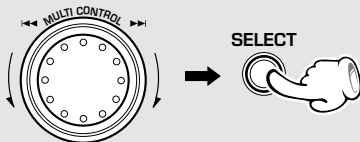

## 4 Start recording.



When recording has been completed, a non-recorded portion of 4 seconds will be produced and the cassette deck part will stop. The CD player will enter temporary stop condition.

To record a different track, repeat the steps 1 to 4.

÷ Select a mode other than random play.

The following items can be selected by turning the MULTI CONTROL jog dial.

- "CD Program Play"
- "Recording Options"
- "Tape Dubbing"
- "Audio Options"
- "Clock Options"
- "Surround Setup"
- "Language Options"

Recording

← Scrolled display (Recording Options)

The following items can be selected by turning the MULTI CONTROL jog dial.

- "CD One-Track Recording"
- (Only during CD playback)
- "CD Direct Recording"
- "CD Program Recording"
- "Timer Recording"

← Scrolled display (CD One-Track Recording)

CD One-Track

← Scrolled display (Press 'ENTER' to Start)

Press 'ENT

÷ Playback restarts from the beginning of the track being played and recording starts at the same time.

## To end recording in the middle

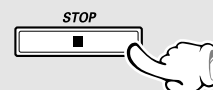

÷ Both the cassette deck and CD player stop.

## Recording of an entire CD (CD DIRECT RECORDING)

Perform the following operation while the CD player is in stop mode to start recording at the same time as the start of playback.



When the equalizer or other effects are applied to the sound, the effect applied to the sound can be recorded. → 46

Recording preparations are required. → 28 (Steps 1 to 4)

### 1 Select "Recording Options".

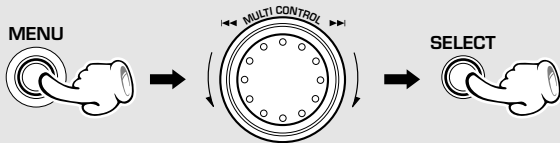

The following items can be selected by turning the MULTI CONTROL jog dial.

"CD Program Play"

"Recording Options"

"Tape Dubbing"

"Audio Options"

"Clock Options"

"Surround Setup"

"Language Options"

← Scrolled display (Recording Options)

Recording

### 2 Select "CD Direct Recording".

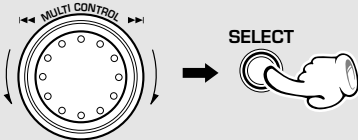

The following items can be selected by turning the MULTI CONTROL jog dial.

"CD Direct Recording"

"CD Program Recording"

"Timer Recording"

← Scrolled display (CD Direct Recording)

CD Direct

### 3 Select the disc.

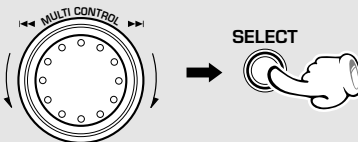

← Scrolled display (Select Disc No.)

Select Dis

Disc No. 1

### 4 Start recording.



← Scrolled display (Press 'ENTER' to Start)

Press 'ENT

- ÷ Recording of CD starts at the same time as playback.
- ÷ At the end of tape, the music is not recorded on the leader tape portion. If you do not want any music to be interrupted in the middle, refer to "Recording on TAPE" and start recording of side B with the interrupted track. → 28

### To end recording in the middle

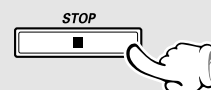

- ÷ Both the cassette deck and CD player stop.

# Recording the programmed titles (CD PROGRAM RECORDING)

Program the desired tracks from up to 3 CD discs in the desired order and record the programmed playback onto tape.



When the equalizer or other effects are applied to the sound, the effect applied to the sound can be recorded. → 46

Recording preparations are required. → 28 (Steps 1 to 4)

## 1 Select "Recording Options".

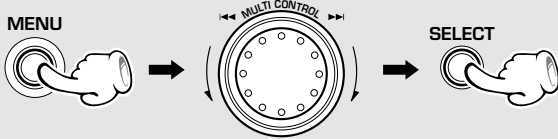

The following items can be selected by turning the MULTI CONTROL jog dial.

- "CD Program Play"
- "Recording Options"
- "Tape Dubbing"
- "Audio Options"
- "Clock Options"
- "Surround Setup"
- "Language Options"

← Scrolled display (Recording Options)

Recording

## 2 Select "CD Program Recording".

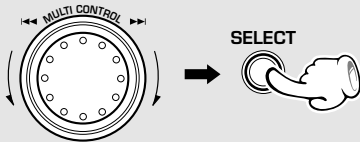

The following items can be selected by turning the MULTI CONTROL jog dial.

- "CD Direct Recording"
- "CD Program Recording"
- "Timer Recording"

Lights



← Scrolled display (CD Program Recording)

CD Program

## 3 Program the desired tracks.

- 1 Select tracks in the order you want to play them. (Perform step 2 on page 32.)
- 2 Check, replace, add or delete the programmed tracks as required. (Perform step 4 on page 33.)

## 4 Start recording.



← Scrolled display  
(Press 'ENTER' to Start, 'JOG' to Check)

Press 'ENT

## To end recording in the middle

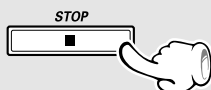

÷ The program mode is maintained even after recording is completed. To return to the normal mode, it is required that the program mode is cancel. → 33

÷ Both the cassette deck and CD player stop.

This unit permits selection of the levels of the equalizer and sound field reproduction effects. Please select the equalizer as desired according to the music genre. Select the sound field mode according to the desired atmosphere.

## Balance adjustment

Adjusts the balance of left and right volume.

÷ "Balance" is not displayed when "S.direct" is selected with the MULTI CONTROL jog dial, etc.

### 1 Select "Audio Options".

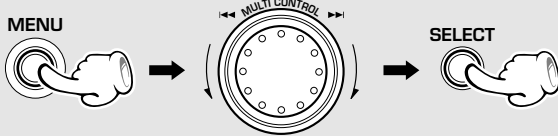

### 2 Select "Balance".

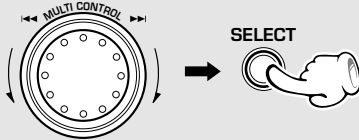

### 3 Adjust.

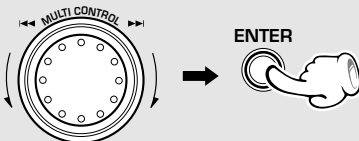

The right volume is decreased

The left volume is decreased

The following items can be selected by turning the MULTI CONTROL jog dial.

- "CD Program Play"
- "Recording Options"
- "Tape Dubbing"
- "Audio Options"**
- "Clock Options"
- "Surround Setup"
- "Language Options"

←Scrolled display (Audio Options)

Audio Opti

The following items can be selected by turning the MULTI CONTROL jog dial.

- "Custom EQ 1"
- "Custom EQ 2"
- "Custom EQ 3"
- "Balance"**
- "DVD/VIDEO Input Level" (Only when the DVD/VIDEO input is selected)
- "Beep Sound"

←Scrolled display (Balance)

Balance

←Scrolled display (Adjust L/R Balance)

Adjust L/R



Indicates the center

L --- \* --- R

Indicates the balance setting

# Input level adjustment

The input level from an external component connected to the AUX or 6CH. INPUT jacks, such as a MD recorder, DVD player, VCR or analog turntable can be adjusted as desired. Adjust so that the volume of the DVD/VIDEO input source sounds at an equivalent level to the CD .

## 1 Select "DVD/VIDEO".

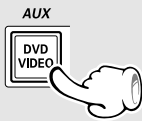

## 2 Select "Audio Options".

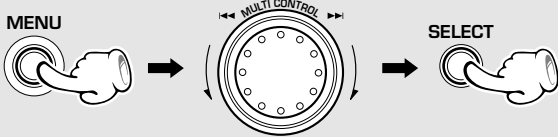

## 3 Select "DVD/VIDEO Input Level".

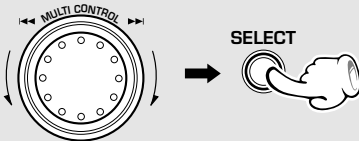

## 4 Adjust.

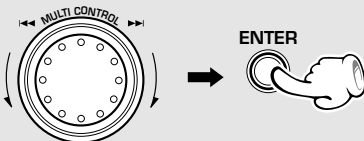

The level is decreased

The level is increased

The following items can be selected by turning the MULTI CONTROL jog dial.

- "CD Program Play"
- "Recording Options"
- "Tape Dubbing"
- **"Audio Options"**
- "Clock Options"
- "Surround Setup"
- "Language Options"

←Scrolled display (Audio Options)

Audio Opti

The following items can be selected by turning the MULTI CONTROL jog dial.

- "Custom EQ 1"
- "Custom EQ 2"
- "Custom EQ 3"
- "Balance" (Only when "S.direct" is not selected)
- **"DVD/VIDEO Input Level"**
- "Beep Sound"

←Scrolled display (DVD/VIDEO Input Level)

DVD/VIDEO

←Scrolled display (Adjust Level)

Adjust Lev

Level

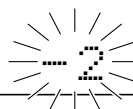

÷ Adjustment is possible in the range of 0 to - 7.

# Listening to music with desired tone and sound field

This unit permits selection of a variety of preset equalizer patterns as well as registration of equalizer patterns created by the user. The "S.direct" (Source direct) mode allows you to reproduce pure sound by bypassing the sound processing circuitry such as the EX.BASS (Extra Bass) and equalizer circuits.

## Selecting the equalizer pattern, DSP playback or surround playback

This unit permits selection of an equalizer pattern, the DSP playback or the surround playback as desired. The equalizer effect applied to the audio can be recorded together with it. (If DSP playback or surround playback is selected, its effect cannot be recorded together with the audio.)

**1** Play desired music.

**2** Select the desired equalizer pattern.

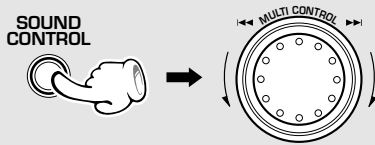

÷ To cancel the equalizer, DSP, surround and "S.direct", select "Effect off".

The following items can be selected by turning the MULTI CONTROL jog dial.

- "Rock" ..... Rock music
- "Pop" ..... Pop music
- "Samba" ..... Samba music
- "Jazz" ..... Jazz music
- "Hall" } \* DSP (Digital Signal Processor) playback
- "Disco" }
- "Church" }
- "Live" }
- "Dolby pro logic" } Surround playback
- "Dolby 3 stereo" }
- "Dolby Virtual surround" }
- "Custom EQ 1" } Equalizer's manual memory created by the user
- "Custom EQ 2" }
- "Custom EQ 3" }
- "S. direct" ..... Pure sound reproduction by turning the EX.BASS, equalizer, DSP play and surround circuitry off.
- "Effect off" ..... Normal playback

The LISTEN MODE key of the remote control unit can be used to select the surround play mode.

Each press switches the modes as follows.

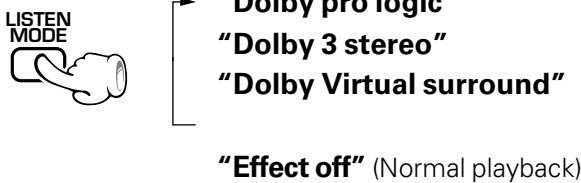

### Surround-related indicators

Lights when "Dolby pro logic" is selected.



Lights when "Dolby Virtual surround" is selected.

Lights when "Dolby 3 stereo" is selected.

÷ The surround play modes that can be selected are variable depending on the surround setting. See "Speakers used and selected surround play modes".

→ 48

### Equalizer/DSP/"S. direct" indicators

Lights when DSP is selected.

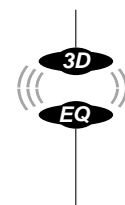

Lights when "S. direct" is selected.

Lights when equalizer is selected.

Check the surround speakers system connection and set up the surround play before starting DSP or surround playback. Please also read "Surround function".

# Equalizer pattern setting and saving

You can edit desired patterns manually and store them in memory.

## 1 Select "Audio Options".

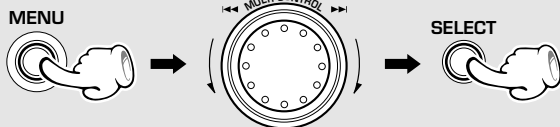

The following items can be selected by turning the MULTI CONTROL jog dial.

- "CD Program Play"
- "Recording Options"
- "Tape Dubbing"
- **"Audio Options"**
- "Clock Options"
- "Surround Setup"
- "Language Options"

← Scrolled display (Audio Options)

Audio Opti

## 2 Select the number to be used for storage. (Custom EQ1 ~ EQ3)

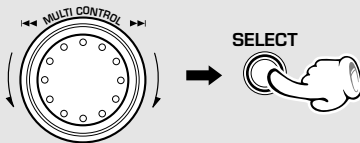

The following items can be selected by turning the MULTI CONTROL jog dial.

- "Custom EQ 1"
- "Custom EQ 2"
- "Custom EQ 3"
- "Balance" (Only when "S.direct" is not selected)
- "DVD/VIDEO Input Level" (Only when the DVD/VIDEO input is selected)
- "Beep Sound"

← Scrolled display (Adjust Bass)

Adjust Bas

Bass

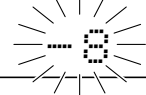

÷ Each frequency band can be adjusted in the range between **- 8** and **+ 8**.

÷ The **"Bass"**, **"Mids"** and **"Highs"** frequency bands can be adjusted independently by repeating step **3** for each of them.

## 3 Adjust the equalizer pattern.

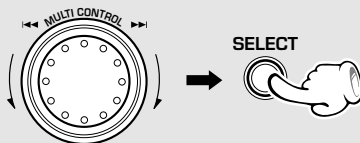

To decrease the level      To increase the level

### \* DSP (Digital Signal Processor) playback

The DSP mode uses the digital processing capability of the DSP to create the reverberation components (factors of sound reflections in a variety of spaces), that determine the feeling of presence, without altering the quality of the music source.



The DSP mode creates the ambiance of a hall, disco, live house or church from any kind of program source. This mode is particularly effective when listening to a stereo program source such as a CD, TV and FM broadcasting. Although the DSP mode can create a simulated stereo surround effect from a monaural source, the proper effect may not be obtained depending on the played software.

## Surround setting

### 1 Select "Surround Setup".

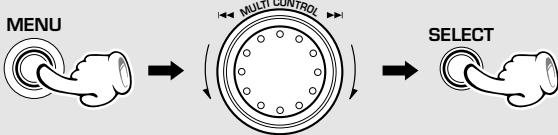

The following items can be selected by turning the MULTI CONTROL jog dial.

- “CD Program Play”
- “Recording Options”
- “Tape Dubbing”
- “Audio Options”
- “Clock Options”
- “Surround Setup”**
- “Language Options”

← Scrolled display (Surround Setup)

Surround S

÷ Be sure to adjust from your listening position.

÷ “Surround Setup” cannot be selected when the selected input is “6ch.Input”.

← Scrolled display (Select Center Speaker)

Select Cen → Small

The following items can be selected by turning the MULTI CONTROL jog dial.

- “Small” ..... When the center speaker is compact-sized speaker
- “Large” ..... When the center speaker is medium- or large-sized speaker
- “No” ..... When the center speaker is not used

← Scrolled display (Select Surround Speaker)

Select Sur → Yes

The following items can be selected by turning the MULTI CONTROL jog dial.

- “Yes” ..... When using surround speakers
- “No” ..... When not using surround speakers

### 2 Select the center speaker size (or select “No” if no center speaker is used at all).

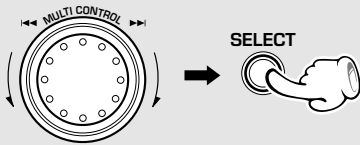

### 3 Select “Yes” if you use the surround speakers.

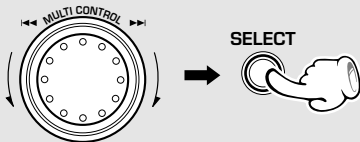

## Speakers used and selected surround play modes

| Center speaker     | Surround speakers | Selectable surround modes                   | Operating procedure |
|--------------------|-------------------|---|---------------------|
| “Small” or “Large” | “Yes”             | Any   | <b>1 2 3 4 5 6</b>  |
| “Small” or “Large” | “No”              | “Dolby 3 stereo”, “Dolby Virtual surround”  | <b>1 2 3 5 6</b>    |
| “No”               | “Yes”             | “Dolby pro logic”, “Dolby Virtual surround” | <b>1 2 3 4 5 6</b>  |
| “No”               | “No”              | “Dolby Virtual surround”                    | <b>1 2 3 6</b>      |

÷ The operations in steps **4** and/or **5** may sometimes be unnecessary when the center and/or surround speakers are set to “No” in the “Surround setting” procedure steps **2** and/or **3**.



#### 4 Select the delay time.

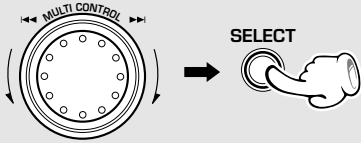

←Scrolled display (Select delay time)

Select del → 20ms

The following items can be selected by turning the MULTI CONTROL jog dial.

- “20ms” ... When the listening position is located between the front and surround speakers
- “30ms” ... When the listening position is closer to the surround speakers
- “15ms” ... When the listening position is closer to the front speakers

#### 5 Adjust the volume balance.

- ① Turn the MULTI CONTROL key while “Test C” or “Test S” is displayed.
- ② Adjust the surround speaker volumes equal to the volume of the test tone from the left and right front speakers.

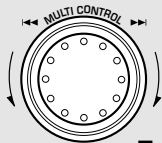

To decrease      To increase

Display for the center speaker volume adjustment :

C-ch      +8

Display for the surround speaker volume adjustment :

S-ch      +8

- ③ After completing the volumes from all the speakers, press the SELECT key.



#### 6 Press the ENTER key.



←Scrolled display (Select Channel Level)

Select Cha → Test L

The display and test tone output speaker are switched automatically.

When adjusting the center speaker and surround speaker volume levels :

- ① “Test L” (Left)
- ② “Test C” (Center)
- ③ “Test R” (Right)
- ④ “Test S” (Surround)

÷ When the center speaker and/or surround speakers are set to “No” in the “Surround setting” procedure steps ② and/or ③, the display and test tone output of the speakers are not provided.

- ÷ Be sure to adjust from your listening position.
- ÷ The volume level can be adjusted in steps of 1 dB.
- ÷ The volume levels can be adjusted in the range from **-10** dB to **+10** dB.
- ÷ The set center level value will be stored as the common setting for “Dolby pro logic” and “Dolby 3 stereo”.

÷ After completion of the settings, the set contents will be displayed by scrolling.

(Center speaker setting → Surround speaker setting → Delay time setting → “Press 'ENTER' to Save”)

To start surround play, select surround playback with the MULTI CONTROL jog dial or LISTEN MODE key.

→ 46

#### Delay time

This refers to the difference in timing of the sound output from the surround speakers with respect to that output from the front speakers. The delay time setting consists of adjusting this difference in time.

## Switching the AUX Input

When playing the source component connected to the AUX jacks (2ch.) or that connected to the 6CH. INPUT jacks (DVD, VIDEO, etc), it is required to switch the AUX input.

With "6ch. Input", the audio from the surround L/R channels becomes monaural.

Each press switches the modes as follows.



- ▶ "DVD(2ch.)" .... (For U.K. and Europe : "DVD")
- ▶ "6ch. Input" ..... (Except for U.K. and Europe)

÷ Press and hold the DVD/VIDEO key for more than 2 seconds. This switches the lighted indicator between "DVD (2ch.)" and "VIDEO".



### Headphone listening :

With "6ch. Input", intended effects cannot be obtained through headphones. When using headphones, be sure to set the source component to the 2ch output setting.

### Tape recording :

With "6ch. Input", correct recording is not possible on tape. When recording a 6CH. INPUT source on tape, be sure to set the source component to the 2ch output setting.



## Surround function

### DSP mode

The DSP mode lets you add the atmosphere of a live concert or hall to PCM or analog of program source. These modes are particularly effective when used with stereo program sources, like CD, television, and FM radio. You might enjoy trying the Hall, Disco, Church, Live mode the next time you watch a concert or sporting event!

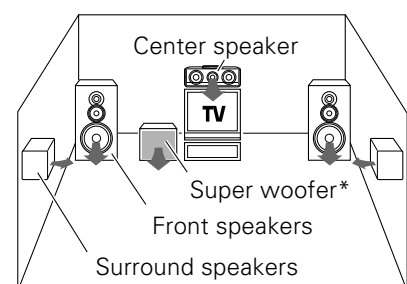

\* Optional in this mode.

### Dolby Pro Logic Surround

When video (LD) software carrying  mark is played, this mode provides the Dolby Surround effect, similar to movie theaters.

Dolby Pro Logic is a specially encoded 2 channel surround format designed to provide theater-like surround sound from Dolby Surround encoded sources (such as video and Laserdisc software marked ).

This unit is equipped with a Dolby Surround decoder to let you enjoy the wide variety of currently available Dolby Surround home video software.

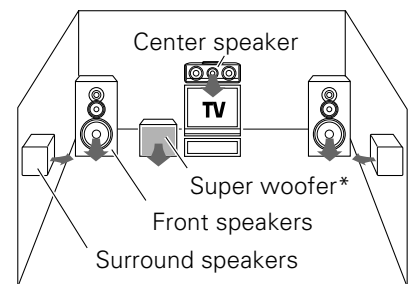

### Dolby 3 Stereo Surround

This mode improves the positioning of the acoustic image of words, etc., by applying directivity enhancer processing and using an additional center speaker when a video software program recorded with ordinary 2-channel stereo is played.

Dolby 3 Stereo is available for systems that do not set surround speakers. When in the Dolby 3 Stereo mode the surround information is redirected to the front left and right speakers. This mode is designed for use with Dolby Surround program sources, but can also improve sound field unity for programs that are not Dolby Surround encoded. Dialog positioning and sound image definition, however, may not be as accurate when used with programs that are not Dolby Surround encoded.

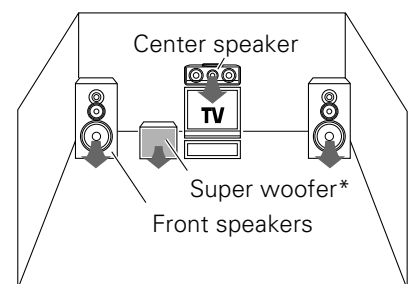

### Dolby Virtual Surround

The surround signals output in the Dolby Pro Logic and Dolby 3 Stereo modes have usually been set to offer rich feeling of presence when five speakers are used.

The Dolby Virtual Surround function offers a simulated surround effect using only the left and right front speakers.

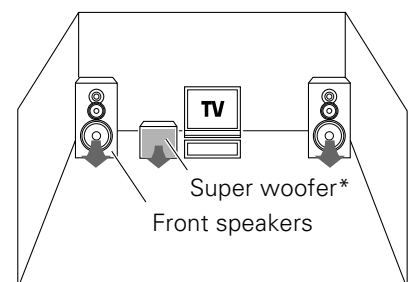

**Sleep timer**

The power is turned OFF automatically after the specified period has elapsed.

**Timer programming**

**Timer playback :** Plays (or receives) the selected source in the set time range.

**AI timer playback** (When timer playback starts, the volume increases gradually.)

**Timer recording :** Records the selected source in the set time range.

**Auto Power Save**

When the power is ON and neither recording nor playback is executed for 30 minutes or more, the power is switched off automatically by this function.

When the volume control is set to 0 or the mute function is on during playback, the Auto Power Save function is also activated.

*Adjust the clock before setting the timer.*



**Sleep timer**

Set the number of minutes after which the power is to be turned OFF.

**1 Select "Clock Options".**

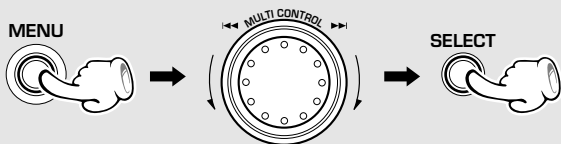

The following items can be selected by turning the MULTI CONTROL jog dial.

- "CD Program Play"
- "Recording Options"
- "Tape Dubbing"
- "Audio Options"
- "Clock Options"**
- "Surround Setup"
- "Language Options"

← Scrolled display (Clock Options)

Clock Opti

The following items can be selected by turning the MULTI CONTROL jog dial.

- "Sleep Timer"**
- "Adjust Time"
- "Timer Play"
- "Auto Power Save"

Lights



Blinks

Sleep 90

10 ↔ 20 ↔ 30 ... 80 ↔ 90 ↔ "Sleep off" ↔ 10 ↔ 20 ...

- ÷ The displayed time changes in 10-minute steps. The maximum time that can be set is 90 minutes.
- ÷ The power is turned OFF automatically after the set time has elapsed.
- ÷ To cancel the sleep timer, turn the power off or select "Sleep off".

**You can also set the sleep time by using the SLEEP key on the remote control unit.**



÷ Each time you press the **SLEEP** key, the sleep time increases in 10-minutes steps.

10 ↔ 20 ↔ 30 ... 80 ↔ 90 ↔ "Sleep off"

## Timer programming

The program timer can set either timer playback or timer recording. Either "Everyday" (executing a timer program once every day) or "One Time" (executing it only once) can be selected for each timer program. Once the time range and content of a timer program has been set, it can be activated or deactivated as desired.

÷ If you made a mistake during timer setting:

Press the **BACK** key to return to the previous step and restart operation from there.

**Adjust the clock before setting the timer.**



### 1 Make preparations for the play (recording).

#### To listen to radio

The stations to be received should already be preset in advance. → 26

#### To listen to CD

Insert a disc. (Program playback is not possible.)  
Select the disc to be played (1, 2 or 3). → 20 → 21

#### To listen to tape

Set a tape in the deck you want to play. → 22

#### Playing or recording the auxiliary input source

Make timer setting of the component connected to the AUX or 6CH. INPUT jacks.

#### For recording

Make preparations for recording. → 28

### 2 Adjust the listening volume.

### 3 Select the timer operation.

#### For timer playback or AI timer playback

#### 1 Select "Clock Options".

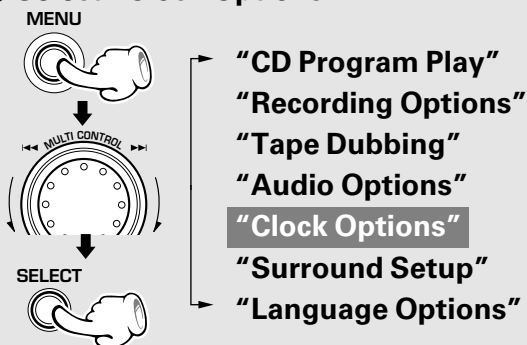

#### 2 Select "Timer Play".

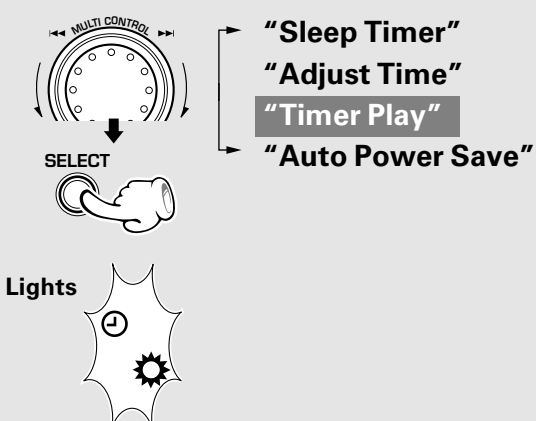

÷ When the timer function is used for timer recording of an input source, the speakers do not output the audio even after the unit is turned on by the timer.

#### For timer recording

#### 1 Select "Recording Options".

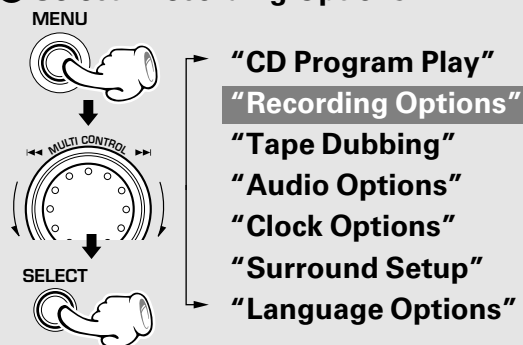

#### 2 Select "Timer Recording".

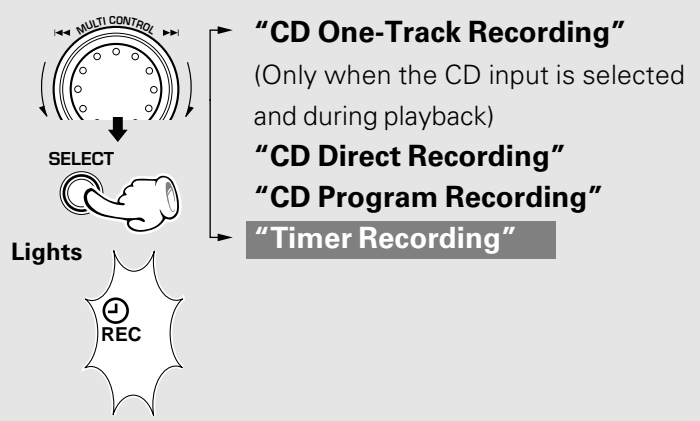

Continued on next page...

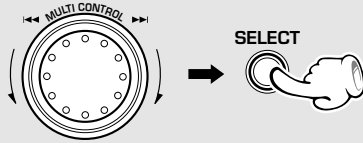
**4** Select "Everyday" or "One Time".

The saved contents cannot be cleared. The contents are cleared only when they are changed.

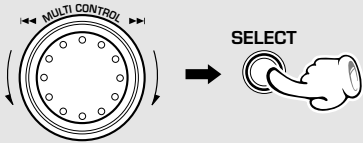
**5** Enter the ON time.

The time is returned      The time is advanced

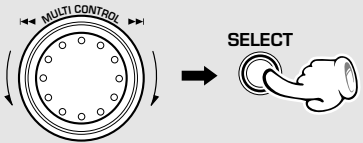
**6** Enter the OFF time.

The time is returned      The time is advanced

The following items can be selected by turning the MULTI CONTROL jog dial.

- └ "Timer off" (Canceled)
- └ "Everyday"
- └ "One Time"

÷ To cancel a timer operation, select "Timer off" under "Timer Play" (in case of timer playback) or "Timer Recording" (in case of timer recording).

← Scrolled display (Select on time)

Select on

on 7:00 on 7:00am

(For U.K. and Europe)

(Other countries)

÷ After entering the "hour", enter the "minute" with the same procedure.

← Scrolled display (Select off time)

Select off

off 7:00 off 7:00am

(For U.K. and Europe)

(Other countries)

÷ After entering the "hour", enter the "minute" with the same procedure.

÷ Set the timer recording program and timer playback program by leaving an interval of 1 minute or more so that their time ranges do not overlap.

**Auto Power Save**

When the power is ON and neither recording nor playback is executed for 30 minutes or more, the power is switched off automatically by this function.

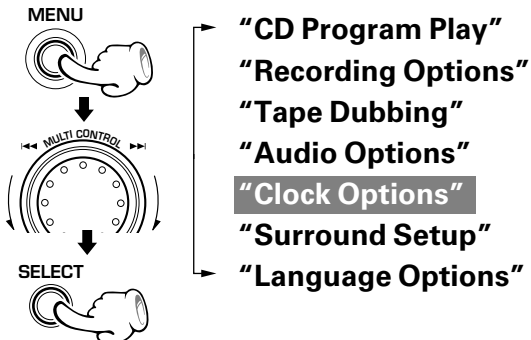
**1** Select "Clock Options".

÷ The auto power save operation does not occur unless program timer operation has completed.

÷ When the TUNER or DVD/VIDEO input is selected, this function works only when the volume is set to zero or the mute function is ON.

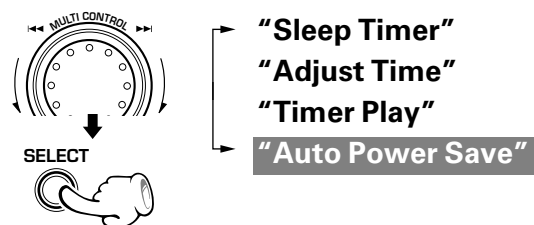
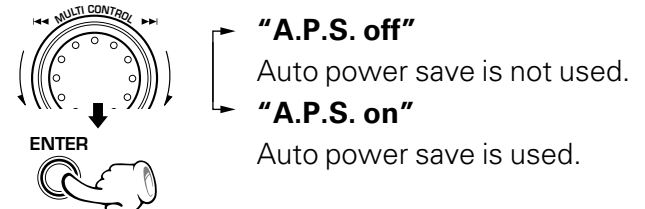
**2** Select "Auto Power Save".**3** Select "A.P.S. on" or "A.P.S. off".

## 7 Make the desired reservation.

### For timer playback or AI timer playback

#### 1 Select the mode.

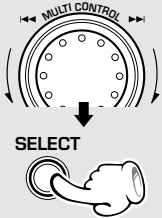

Select "Timer Play" or "AI Play".

- ① "Timer Play" .. Timer play
- ② "AI Play" .. Timer play with gradually increasing volume

#### 2 Select the input source.

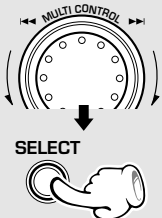

Select the source to be played.

- ① "TUNER" ... Radio
- ② "CD"
- ③ "TAPE"
- ④ "DVD/VIDEO" ... External input

#### 3 Select the broadcast station (only when "TUNER" is selected above).

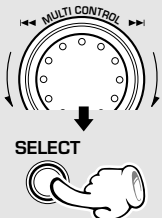

Select the preset station No.



### For timer recording

#### 1 Select the input source.

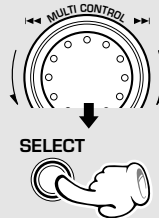

Select the recorded input source.

- ① "TUNER" ..... Radio
- ② "DVD/VIDEO" .... External input

#### 2 Select the broadcast station (only when TUNER is selected above).

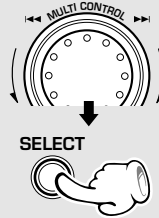

Select the preset station No.



←Scrolled display (Press 'ENTER' to Save, 'JOG' to Check)

Press 'ENT

If you turn the **MULTI CONTROL** jog dial:

÷ The set program content items are displayed one after another.

"Everyday" or "One Time" → On time → Off time → Mode → Input source → Preset channel (only tuner)

When you press the **SELECT** key, you can change the settings. Operate the procedure from step 4 on page 54.

## 8 Press the ENTER key.



## 9 Put the unit in standby mode.

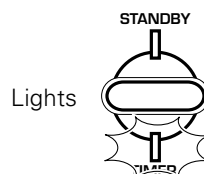
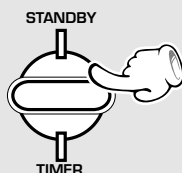

Lights

÷ If the **TIMER** indicator is blinking now, set the time of the day again.

**Disc handling precautions**

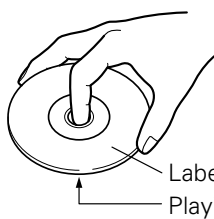

**Handling**  
Hold the discs so that you do not touch the playing surface.

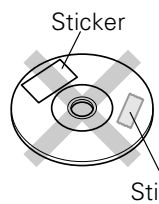

Do not attach paper or tape to either the playing side or the label side of the discs.

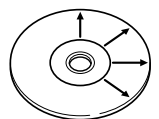

**Cleaning**  
If fingerprints or foreign matter become attached to the disc, lightly wipe the disc with a soft cotton cloth (or similar) from the center of the disc outwards in a radial manner.

**Storage**  
When a disc is not to be played for a long period of time, remove it from the player and store it in its case.

**Discs which can be played with this unit**

CD (12 cm, 8 cm), and the audio part of CDV, CD-G, CD-EG and CD-EXTRA.

Use discs that comply with the IEC standard, for example a disc carrying the  marking on the label surface.

**Never play a cracked or warped disc**

During playback, the disc rotates at high speed in the player. Therefore, to avoid danger, never use a cracked or deformed disc or a disc repaired with tape or adhesive agent. Please do not use discs which are not round because they may cause a malfunction.

**Disc accessories**

The disc accessories (stabilizer, protection sheet, protection ring, etc.) which are marketed for improving the sound quality or protecting discs as well as the disc cleaner should not be used with this system because they may cause malfunction.

**Notes on cassette tape**

**Safety tab (accidental erasure prevention tab)**

After an important recording has been finished, break the safety tab, to prevent the recorded contents from being erased or recorded on accidentally.

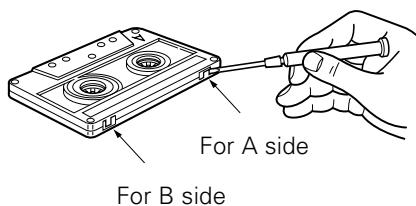

**To store cassette tapes**

Do not store the tapes in a place which is subject to direct sunlight, or near equipment that generates heat. Keep the cassette tapes away from any magnetic field.

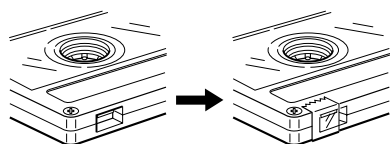
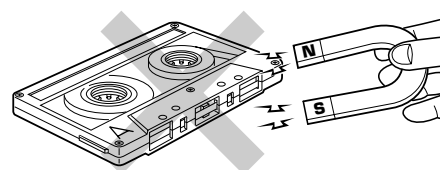

**To re-record** Apply tape only to the position where the tab has been removed.

**When there is slack in the tape**

In such a case, insert a pencil into the reel hole and wind the reel hub to remove the slack.

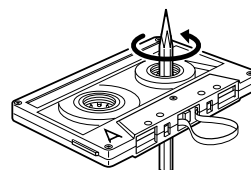

**1. Cassette tapes that are longer than 100 minutes**

Since tapes that are longer than 100 minutes are very thin, the tape could adhere to the pinch roller or be easily cut. It is recommended that these tapes not be used with this unit to prevent possible damage.

**2. Endless tapes**

Do not use an endless tape, as this could damage the mechanism of the unit.





## Maintenance

### Cleaning the head section

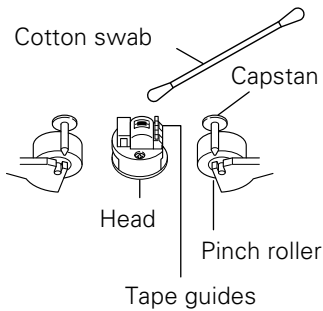

### Cleaning the heads and peripheral components

For maintaining the best condition of the deck and for longer service life, always keep the heads (recording / playback / erase), capstan and pinch roller clean. To clean them, perform the following:

1. Open the cassette holder.
2. Using a cotton swab dipped in alcohol, clean the head (recording / playback / erase), capstan and pinch roller carefully.

### Demagnetizing the head

When the recording / playback head is magnetized, the sound quality will deteriorate. In such a case, demagnetize the head using a commercially available demagnetizer (head eraser).



There are precisely aligned parts around the heads, including the tape guides. When cleaning, pay special attention so as not to apply shock to them.

### Maintenance of the unit

When the front panel or case becomes dirty, wipe with a soft, dry cloth. Do not use thinner, benzene, alcohol, etc. for these agents may cause discoloration.

### In regard to contact cleaner

Do not use contact cleaners because it could cause a malfunction. Be specially careful not to use contact cleaners containing oil, for they may deform the plastic component.

## Reference

### Caution on condensation

Condensation (of dew) may occur inside the unit when there is a great difference in temperature between this unit and the outside. This unit may not function properly if condensation occurs. In this case, leave the unit for a few hours with the power left ON, and restart the operation after the condensation has dried up.

Be specially cautious against condensation in a following circumstance:

When this unit is carried from a place to another across a large difference in temperature, when the humidity in the room where this unit is installed increases, etc.

### Notes related to transportation and movement

Before transporting or moving this unit, carry out the following procedures.

- 1 Turn the power ON but do not load a disc.
- 2 Press the CD (▶/II) key.
- 3 Wait a few seconds, and ensure that the display is as shown below.

No Disc

- 4 Wait for a few seconds then turn power off.

Manufactured under license from Dolby Laboratories. "DOLBY", the double-D symbol and "PRO LOGIC" are trademarks of Dolby Laboratories.

### Memory backup function

|  |  |
|--|--|
| <b>Stored contents which are cleared immediately when power plug is unplugged from power outlet</b>        | Clock display  |
| <b>Stored contents which are cleared in at least a day after power plug is unplugged from power outlet</b> | <b>Amplifier</b><br>POWER status (ON or OFF)<br>Input selection<br>Volume control value<br>Balance level<br>Equalizer's manual memory created by the user<br>DVD/VIDEO input level<br>Auto Power Save<br><b>Tuner unit</b><br>Receiving band<br>Frequency<br>Preset stations<br>Program timer setting contents<br><b>Cassette deck unit</b><br>Transport direction<br>Tape Equalizer<br>Reverse mode<br><b>Other</b><br>Language |

### WARNING NOTICE:

IN MOST CASES IT IS AN INFRINGEMENT OF COPYRIGHT TO MAKE COPIES OF TAPES OR DISCS WITHOUT THE PERMISSION OF THE COPYRIGHT OWNERS. ANYONE WISHING TO COPY COMMERCIALY AVAILABLE TAPES OR DISC SHOULD CONTACT THE MECHANICAL COPYRIGHT PROTECTION SOCIETY LIMITED OR THE PERFORMING RIGHTS SOCIETY LIMITED.

What seems to be a malfunction is not always so. Before calling for service, check the following table according to the symptom of your trouble.

**Operation to reset**

The microcomputer may fall into malfunction (impossibility to operate, erroneous display, etc.) when the power cord is unplugged while power is ON or due to an external factor. In this case, execute the following procedure to reset the microcomputer and return it to normal condition.

**Unplug the power cord from the power outlet then, while holding the ENTER key depressed, plug the power cord again.**







(Main unit only)







÷ Please note that resetting the microcomputer clears the stored contents and returns to the factory set condition.

**Receiver, speakers**

| Symptom  | Cause   | Remedy  |
|--|---|---|
| Sound is not produced.   | ÷ The speaker cords are disconnected.<br>÷ The <b>MUTE</b> switch of remote control unit is switched ON.<br>÷ The headphone plug is inserted into the jack.   | ÷ Connect properly referring to " <b>System connection</b> ". → 6 → 7<br>÷ Switch <b>MUTE</b> OFF. → 19<br>÷ Unplug the headphone plug. → 18  |
| "STANDBY" and "TIMER" indicators blink alternately and no sound is output. | ÷ The speaker cords are short-circuited.  | ÷ Turn the power OFF, remove the short-circuit and turn the power ON again.   |
| Sound is not produced from the left or right speakers.                     | ÷ The speaker cords are disconnected.<br>÷ The left and right volumes are not balanced.   | ÷ Connect properly referring to " <b>System connection</b> ". → 6 → 7<br>÷ Adjust the left and right volume balance. → 44   |
| "Dolby pro logic" and "Dolby 3 stereo" cannot be selected.                 | ÷ The center speaker and surround speakers are set to " <b>No</b> ".  | ÷ Perform the center speaker and surround speaker setting operations properly. → 48   |
| The clock display blinks.  | ÷ There was a power failure.<br>÷ The power cord was unplugged from the outlet.   | ÷ Adjust the present time again. → 16<br>÷ Adjust the present time again. → 16  |
| Timer operation is not possible.   | ÷ The present time has not been adjusted or there was a power failure.<br>÷ The timer program or the timer ON/OFF time has not been set properly.             | ÷ Adjust the present time referring to " <b>Clock adjustment</b> ". → 16<br>÷ Check the timer program and set its ON/OFF time properly. Note that " <b>Everyday</b> " and " <b>One Time</b> " cannot be set simultaneously for a single timer program. → 54 |
| Radio stations cannot be received.   | ÷ The antennas have not been connected.<br>÷ A proper broadcasting band has not been selected.<br>÷ The frequency of the station to be received is not tuned. | ÷ Connect antennas. → 5<br>÷ Select a band. → 26<br>÷ Tune to the frequency of the desired station. → 26  |
| Sound from the DVD/VIDEO INPUT (external input) is distorted.              | ÷ The input level is too high.  | ÷ Decrease the input level. → 45  |

|   |  |  |
|---|--|--|
| <b>Noise interferes.</b>                                    | <ul style="list-style-type: none"> <li>÷ Car ignition noise.</li> <li>÷ Influence of an electric appliance.</li> <li>÷ A TV set is installed near the system.</li> </ul>   | <ul style="list-style-type: none"> <li>÷ Install the outdoor antenna in an apart position from the road.</li> <li>÷ Switch the suspected electric appliance OFF.</li> <li>÷ Increase the distance between the sets. →  6</li> </ul> |
| <b>No station can be received by preset call operation.</b> | <ul style="list-style-type: none"> <li>÷ The frequency of the preset station is not tunable.</li> <li>÷ The preset memory has been cleared because the power cord has been unplugged for a long period.</li> </ul> | <ul style="list-style-type: none"> <li>÷ Preset stations with tunable frequencies. →  27</li> <li>÷ Preset stations again. →  27</li> </ul>      |
| <b>Demonstration starts suddenly.</b>                       | <ul style="list-style-type: none"> <li>÷ The power plug was unplugged from the outlet while the power switch was ON, or there was a power failure.</li> </ul>  | <ul style="list-style-type: none"> <li>÷ This is not a malfunction. Press the <b>DISPLAY/DEMO</b> key to cancel the demonstration. →  4</li> </ul>  |
| <b>Power turns OFF in the middle of operation.</b>          | <ul style="list-style-type: none"> <li>÷ "A.P.S. on" is set.</li> </ul>  | <ul style="list-style-type: none"> <li>÷ Set it to "A.P.S. off". →  54</li> </ul>   |
| <b>"Tape Dubbing" is not displayed in the menu.</b>         | <ul style="list-style-type: none"> <li>÷ The DSP play or surround play pattern is selected.</li> </ul>   | <ul style="list-style-type: none"> <li>÷ Select other equalizer pattern than the DSP play and surround play patterns. →  46</li> </ul>  |

### Cassette deck

| Symptom   | Cause   | Remedy  |
|---|---|---|
| <b>Sound cannot be produced by pressing the play key.</b>                       | <ul style="list-style-type: none"> <li>÷ The head is dirty.</li> <li>÷ The tape is wound too tight due to irregular winding.</li> <li>÷ A nonrecorded tape is played.</li> </ul>  | <ul style="list-style-type: none"> <li>÷ Clean the head referring to "Maintenance". →  57</li> <li>÷ Try another tape.</li> <li>÷ Play a recorded tape.</li> </ul>   |
| <b>No operation occurs even when an operation key is pressed.</b>               | <ul style="list-style-type: none"> <li>÷ The cassette holder is not closed completely.</li> <li>÷ The operation key is pressed immediately after closing the cassette holder.</li> <li>÷ The operation key is pressed in less than 4 seconds after turning the power ON.</li> <li>÷ A tape is not inserted in the unit.</li> <li>÷ The tape is wound too tight due to irregular winding.</li> <li>÷ The tape is fully wound to one of the reels.</li> </ul> | <ul style="list-style-type: none"> <li>÷ Close the holder completely. →  22</li> <li>÷ Press operations keys in more than a few seconds after closing the holder.</li> <li>÷ Press operation keys after waiting for more than 4 seconds.</li> <li>÷ Insert a tape. →  22</li> <li>÷ Try another tape.</li> <li>÷ Change the tape transport direction or reverse the tape insertion orientation. →  22</li> </ul> |
| <b>In dubbing, the tape stops at different moments in decks A and B.</b>        | <ul style="list-style-type: none"> <li>÷ This is due to the difference in the tape length or characteristics of the mechanisms of two cassette decks.</li> </ul>  | <ul style="list-style-type: none"> <li>÷ Small time difference does not mean a malfunction.</li> </ul>  |
| <b>The cassette holders cannot be opened by pressing the PUSH OPEN (▲) key.</b> | <ul style="list-style-type: none"> <li>÷ The key is pressed during recording or playback.</li> <li>÷ The microcomputer is malfunctioning due to external noise.</li> </ul>  | <ul style="list-style-type: none"> <li>÷ Press in stop mode.</li> <li>÷ Reset the microcomputer. →  58</li> </ul>  |



1. With some tapes, a squeaky noise is produced when the tape is stopped automatically. This is due to the tape protection function, and not a malfunction.
2. Do not use longer tape than 100 minutes tapes, for the tape is too thin and gets easily tangled.

|  |   |   |
|--|---|---|
| <b>Sound is harsh or high frequencies are not reproduced.</b>  | <ul style="list-style-type: none"> <li>÷ The head is dirty.</li> <li>÷ The tape is stretched or shrunk.</li> </ul>  | <ul style="list-style-type: none"> <li>÷ Clean the head referring to <b>"Maintenance"</b>. → 57</li> <li>÷ Try another tape.</li> </ul>   |
| <b>Sound is distorted.</b>                                     | <ul style="list-style-type: none"> <li>÷ The tape being played was recorded with distorted sound.</li> <li>÷ A tape which has been recorded with the equalizer and/or surround effects is being played back by applying the equalizer effect.</li> </ul>                      | <ul style="list-style-type: none"> <li>÷ Try another tape.</li> <li>÷ Switch off the equalizer and surround effects before starting playback. → 46</li> </ul>   |
| <b>Noise is noticeable.</b>                                    | <ul style="list-style-type: none"> <li>÷ The tape head is magnetized.</li> <li>÷ External noise is induced.</li> <li>÷ A tape which has been recorded with Dolby NR is being played back without switching the Tape Equalizer.</li> </ul>                                     | <ul style="list-style-type: none"> <li>÷ Demagnetize the head referring to <b>"Maintenance"</b>. → 57</li> <li>÷ Install the system at a distance from other electric appliances and TV.</li> <li>÷ Switch on the Tape Equalizer. → 23</li> </ul>   |
| <b>Sound vibrates.</b>   | <ul style="list-style-type: none"> <li>÷ The capstans or pinch rollers are dirty.</li> <li>÷ The tape is wound irregularly.</li> </ul>  | <ul style="list-style-type: none"> <li>÷ Clean the head referring to <b>"Maintenance"</b>. → 57</li> <li>÷ Wind the tape again by fast forwarding, rewinding or playing from an end to the other. → 23</li> </ul>   |
| <b>Recording cannot be started by pressing the record key.</b> | <ul style="list-style-type: none"> <li>÷ The recording protect tab of the cassette has been broken.</li> <li>÷ The cassette holder is not closed completely.</li> <li>÷ The <b>TAPE</b> input is selected.</li> <li>÷ The tape is fully wound to one of the reels.</li> </ul> | <ul style="list-style-type: none"> <li>÷ Use a cassette with an unbroken recording protect tab or block the hole. → 56</li> <li>÷ Close the holder completely. → 22</li> <li>÷ Select the source to be recorded with the <b>CD</b>, <b>TUNER</b>, or <b>AUX</b> key. → 29</li> <li>÷ Change the tape transport direction of deck B or reverse the tape insertion orientation. → 28</li> </ul> |

### CD player

| Symptom  | Cause  | Remedy   |
|--|--|--|
| <b>A CD is placed in the player but it cannot be played.</b> | <ul style="list-style-type: none"> <li>÷ The disc is placed upside down.</li> <li>÷ The disc position is displaced.</li> <li>÷ The disc is extremely dirty.</li> <li>÷ The disc is scratched.</li> <li>÷ Dew is condensed on the optics lens.</li> </ul> | <ul style="list-style-type: none"> <li>÷ Place the disc properly, with the label side facing upward. → 20</li> <li>÷ Place the disc properly. → 20</li> <li>÷ Clean the disc referring to <b>"Handling of discs and tapes"</b>. → 56</li> <li>÷ Try another disc.</li> <li>÷ Refer to <b>"Caution on condensation"</b> and remove the condensation by evaporation. → 57</li> </ul> |
| <b>Sound is not produced.</b>                                | <ul style="list-style-type: none"> <li>÷ The disc has not been placed.</li> <li>÷ The player is not set to the play mode.</li> <li>÷ The disc is extremely dirty.</li> <li>÷ The disc is scratched.</li> </ul>   | <ul style="list-style-type: none"> <li>÷ Place a disc in the CD player. → 20</li> <li>÷ Press the play key. → 20</li> <li>÷ Clean the disc referring to <b>"Handling of discs and tapes"</b>. → 56</li> <li>÷ Try another disc.</li> </ul>   |
| <b>Sound skips.</b>  | <ul style="list-style-type: none"> <li>÷ The disc is dirty.</li> <li>÷ The disc is scratched.</li> <li>÷ The player was subjected to vibration.</li> </ul>   | <ul style="list-style-type: none"> <li>÷ Clean the disc referring to <b>"Handling of discs and tapes"</b>. → 56</li> <li>÷ Try another disc.</li> <li>÷ Install the unit in a place not subject to vibrations.</li> </ul>  |

**Remote control unit**

| Symptom  | Cause  | Remedy  |
|--|--|---|
| <b>Remote control operation is not possible.</b> | <ul style="list-style-type: none"> <li>÷ Batteries are exhausted.</li> <li>÷ The remote control is too far away from the system, the controlling angle is deviated or there is an obstacle in between.</li> <li>÷ There is no tape or CD set in the component to be played.</li> <li>÷ An attempt is made to play the cassette deck which is recording something.</li> <li>÷ The MULTI CONTROL setting mode is activated.</li> </ul> | <ul style="list-style-type: none"> <li>÷ Replace with new batteries. → 14</li> <li>÷ Operate the unit within the remote controllable range. → 14</li> <li>÷ Set a tape or CD in the component to be played.</li> <li>÷ Wait until the recording ends.</li> <li>÷ Cancel the MULTI CONTROL setting mode. → 15</li> </ul> |

**General**

| Symptom  | Cause  | Remedy  |
|--|--|---|
| <b>No operation occurs when an operation key is pressed.</b> | <ul style="list-style-type: none"> <li>÷ The MULTI CONTROL setting mode is activated.</li> </ul> | <ul style="list-style-type: none"> <li>÷ Cancel the MULTI CONTROL setting mode. → 15</li> </ul> |

**For the U.S.A.**

**CAUTION :**

Use of controls or adjustments or performance of procedures other than those specified herein may result in hazardous radiation exposure.

In compliance with Federal Regulations, following are reproductions of labels on, or inside the product relating to laser product safety.

**KENWOOD CORPORATION  
2967-3, ISHIKAWA-CHO,  
HACHIOJI-SHI, TOKYO, JAPAN**

**KENWOOD CORP. CERTIFIES THIS EQUIPMENT  
CONFORMS TO DHHS REGULATIONS NO. 21 CFR  
1040.10, CHAPTER 1, SUBCHAPTER J.**

Location: Back Panel

**Note to CATV system installer**

This reminder is provided to call the CATV system installer's attention to Article 820-40 of the NEC that provides guidelines for proper grounding and, in particular, specifies that the cable ground shall be connected to the grounding system of the building, as close to the point of cable entry as practical

**FCC WARNING**

This equipment may generate or use radio frequency energy. Changes or modifications to this equipment may cause harmful interference unless the modifications are expressly approved in the instruction manual. The user could lose the authority to operate this equipment if an unauthorized change or modification is made.

**NOTE:**

This equipment has been tested and found to comply with the limits for a Class B digital device, pursuant to Part 15 of the FCC Rules. These limits are designed to provide reasonable protection against harmful interference in a residential installation. This equipment may cause harmful interference to radio communications, if it is not installed and used in accordance with the instructions. However, there is no guarantee that interference will not occur in a particular installation. If this equipment does cause harmful interference to radio or television reception, which can be determined by turning the equipment off and on, the user is encouraged to try to correct the interference by one or more of the following measures:

- Reorient or relocate the receiving antenna.
- Increase the separation between the equipment and receiver.
- Connect the equipment into an outlet on a circuit different from that to which the receiver is connected.
- Consult the dealer or an experienced radio / TV technician for help.

**Main unit**

**[ Amplifier section ]**

Rated power output  
(For U.S.A. and Canada)

65 watts per channel minimum RMS, both channels driven, at 6 Ω form 40 Hz to 15 kHz with no more than 0.9 % total harmonic distortion. (FTC)

(For U.K. and Europe)  
1 kHz, 0.7 % T.H.D., 6 Ω ..... (DIN) 65 W + 65 W  
(Other countries)  
1 kHz, 1 % T.H.D., 6 Ω ..... (RMS) 85 W + 85 W

Effective output power during SURROUND operation (One channel driven)

(For U.S.A. and Canada)  
FRONT(1 kHz, 10 % T.H.D., 6 Ω ) ... (RMS) 110 W + 110 W  
CENTER(1 kHz, 10 % T.H.D., 6 Ω ) ..... (RMS) 35 W  
REAR(1 kHz, 10 % T.H.D., 12 Ω ) .. (RMS) 17.5 W + 17.5 W  
(Other countries)  
FRONT(1 kHz, 10 % T.H.D., 6 Ω ) ... (RMS) 100 W + 100 W  
CENTER(1 kHz, 10 % T.H.D., 6 Ω ) ..... (RMS) 35 W  
REAR(1 kHz, 10 % T.H.D., 12 Ω ) .. (RMS) 17.5 W + 17.5 W

Effective Music power (DIN) (One channel driven)

(For U.K. and Europe)  
FRONT ..... 200 W + 200 W  
CENTER ..... 50 W  
REAR ..... 25 W + 25 W

Signal to noise ratio  
DVD/VIDEO INPUT ..... 92 dB (IHF' 66)

Input sensitivity / inpedance  
DVD/MD INPUT ..... 270 mV / 47 kΩ

(Except for U.K. and Europe)  
6ch. FRONT (L/R) ..... 430 mV / 33 kΩ  
6ch. CENTER ..... 240 mV / 22 kΩ  
6ch. SURROUND (L/R) ..... 240 mV / 33 kΩ  
6ch. SUB WOOFER ..... 47 mV / 33 kΩ

Output Level / inpedance  
SUPER WOOFER ..... 2.0V / 600 kΩ

**[ Tuner section ]**

FM tuner section  
Tuning frequency range ..... 87.5 MHz ~ 108 MHz

MW (AM) Tuner section  
Tuning frequency range  
(For U.S.A. and Canada) ..... 530 kHz ~ 1,700 kHz  
(For U.K. and Europe) ..... 531 kHz ~ 1,602 kHz  
(Other countries)  
9 kHz step ..... 531 kHz ~ 1,602 kHz  
10 kHz step ..... 530 kHz ~ 1,610 kHz

LW Tuner section (For U.K.)  
Tuning frequency range ..... 153 kHz ~ 279 kHz

**[ Cassette deck section ]**

Track ..... 4-track, 2-channel stereo  
Recording system ..... AC bias system  
(Frequency: 105 kHz)

Heads  
A deck Playback head ..... 1  
B deck Playback / recording head ..... 1  
Erasing head ..... 1  
Fast winding time ..... Approx. 115 seconds  
(C-60 tape)

**[ CD player section ]**

Laser wave length ..... 770 to 795 nm  
Laser power class ..... Class 3A  
Wow & Flutter ..... Less than unmeasurable Limit  
(Except for U.S.A. and Canada)  
Digital output (Optical) ..... - 15 dBm ~ - 21 dBm  
(Wave length 660 nm)

**[ General ]**

Power consumption ..... 150 W  
Dimensions ..... W : 270 mm (10-5/8")  
H : 330 mm (13")  
D : 390 mm (15-3/8")  
Weight (net) ..... 8.3 kg (18.3 lb)

 1.KENWOOD follows a policy of continuous advancements in development. For this reason specifications may be changed without notice.  
2.Sufficient performance may not be possible at very low temperatures (0°C or less).



This instruction manual is used to describe multiple models.  
 Model availability and features (functions) may differ depending on the country and sales area.



|   |   | XD-A83 | XD-853                                   | XD-803                                   |
|---|---|--------|--|--|
| <b>DIGITAL OUT OPTICAL jack</b><br>→  8 | ▶ | —      | YES                                      | YES                                      |
| <b>6CH. INPUT</b><br>→  8               | ▶ | YES    | YES<br>( Except for U.K.<br>and Europe ) | YES<br>( Except for U.K.<br>and Europe ) |
| <b>Beat cancel function</b><br>→  30    | ▶ | —      | YES<br>( For U.K. )                      | YES<br>( For U.K. )                      |
| <b>R.D.S</b><br>→  37                   | ▶ | —      | YES<br>( For U.K. and<br>Europe )        | YES<br>( For U.K. and<br>Europe )        |

# KENWOOD

### *For your records*

Record the serial number, found on the back of the unit, in the spaces designated on the warranty card, and in the space provided below. Refer to the model and serial numbers whenever you call upon your dealer for information or service on this product.

Model \_\_\_\_\_ Serial Number \_\_\_\_\_